



**Instruction Manual**  
**DS10**  
**10 Inch Industrial Disc Sander**

---

**Kalamazoo Industries, Inc.**

6856 E K Ave • Kalamazoo, Michigan 49048

1-800-592-2050 • [www.kalamazooind.com](http://www.kalamazooind.com)

**Made in the USA • Est. 1960**

## 1. Introduction

The DS10 is powered by a 1/2 HP motor available in single-phase 115V or 230V configuration. Equipped with a direct-drive system, a 10-inch aluminum disc, an adjustable steel locking tilt table, and a steel disc guard, the DS10 delivers clean, square results on edges, ends, and miter surfaces. The fully serviceable all-steel construction ensures long-term operational reliability.

This manual must be read in its entirety prior to installation, commissioning, or operation of the equipment. Thorough familiarity with the unit's capabilities, safety requirements, and prescribed maintenance procedures is essential to safe operation and optimal performance.

### **CAUTION:**

The DS10 disc sander is designed for use on wood, plastics, and light non-ferrous materials with appropriate abrasive discs. Do not use for wet materials. Always use appropriate personal protective equipment. Sanding discs must be changed before use if worn or damaged. Use only PSA-type sanding discs rated for the 1725 RPM operating speed.

### **⚠ WARNING:**

TO REDUCE THE RISK OF FIRE, ELECTRIC SHOCK, OR PERSONAL INJURY, ALL SAFETY INSTRUCTIONS MUST BE READ AND UNDERSTOOD BEFORE OPERATING THIS EQUIPMENT. Non-compliance with these guidelines may result in serious injury or death.

## 2. Safety Information

### 2.1 General Safety Precautions

1. Personal protective equipment (PPE) must be worn at all times during operation, including safety glasses or face shield, hearing protection, and a dust mask or respirator appropriate for the material being processed.
2. The work area must be kept clean, organized, and adequately illuminated at all times.
3. This equipment must not be operated by personnel under the influence of drugs, alcohol, or any medication that may impair judgment or reaction time.
4. The unit must not be left running unattended.
5. Power must be disconnected prior to performing any maintenance, disc changes, or adjustments.
6. The unit must be positioned on a level, stable surface during all operations.
7. Unauthorized personnel must be kept clear of the operating machine at all times.
8. Never reach into the sanding area while the disc is in motion or coasting to a stop.
9. Keep hands, hair, and loose clothing well clear of the rotating disc and all moving parts.
10. Do not wear gloves.

## 2.2 Electrical Safety

- The machine must be properly grounded prior to operation in accordance with applicable electrical codes.
- Confirm that facility voltage matches the unit's configuration before making any electrical connection.
- All electrical installation and repair work must be performed by a qualified electrician.
- The unit must not be operated if wiring or electrical components show signs of damage or deterioration.
- Power supply cords must be routed to prevent tripping hazards and contact with moving parts.

## 2.3 Disc Safety

### **⚠ WARNING:**

DISCONNECT POWER before changing or inspecting the sanding disc. Never attempt to change a disc while the unit is energized or coasting to a stop.

- Inspect the sanding disc before each use. Discard any disc that is torn, delaminating, or otherwise damaged.
- Use only PSA (pressure-sensitive adhesive) sanding discs rated for the 10-inch, direct-drive configuration.
- Verify the disc is fully adhered to the aluminum disc plate with no lifting edges before operating.
- Do not apply excessive lateral force. Let the abrasive do the work.
- Never wear loose clothing, ties, or gloves that could become entangled in the rotating disc.

## 2.4 Dust and Chip Safety

- Sanding produces fine dust particles. Keep all flammable materials clear of the work area.
- Never use this machine on materials that produce toxic dust without appropriate respiratory protection and dust containment measures.
- Clean accumulated dust and debris from the unit and work area after each use.

## 3. Warranty Information

### 3.1 Warranty Coverage

All parts are warranted for one year from the original date of purchase to the original purchaser. This warranty covers the replacement of parts found to be defective in material or workmanship under normal use. Some exclusions may apply.

### 3.2 Warranty Exclusions

This warranty does not cover:

- Normal wear items including abrasive discs and bearings.
- Damage resulting from misuse, abuse, or improper maintenance.
- Damage from sanding inappropriate or incompatible materials.
- Modifications or alterations to the machine.
- Damage caused by improper electrical connection or voltage supply.
- Labor or installation costs.

This warranty is non-transferable and applies only to the original purchaser.

### 3.3 Return Authorization

A Return Authorization (RA) number must be obtained before returning any merchandise. Contact Customer Service at 1-800-592-2050 to request authorization. Items returned without prior authorization may not be accepted.

- Return shipping costs are the responsibility of the customer.
  - Credit issued upon inspection.
  - A 10% restocking fee applies to all returns.
  - The restocking fee is waived if a replacement order is placed prior to the return
-

ITEM NO.	PART NUMBER	DESCRIPTION	QTY.
1	050-022	BASE (HORI) FOR DS10	1
2	486-011	1/2HP MOTOR FOR BELT AND DISC	1
3	HHC303 016	5/16-18 X 1 HHCS GR5 Z	4
4	UPWZ031	5/16 USS FW Z	12
5	SLWZ031	5/16 SHUT L/W Z	8
6	PHNS031	5/16-18 PHN GR5 ZINC	4
7	160-001-REV1	DS10 SERIES TOP DISC HOLDER ASSEMBLY-REVISION 1	1
8	342-029	GUARD DISC FOR DS10	1
9	HHC303 012	5/16-18 X 3/4 HHCS GR5 Z	4
10	929-014	TABLE WORK DISC SANDER FOR DS10, DS10.4 AND DS10.2AM	1
11	441-017	KNOB FOR DS10, DS10.4S AND DS1.2 WORK TABLES	2

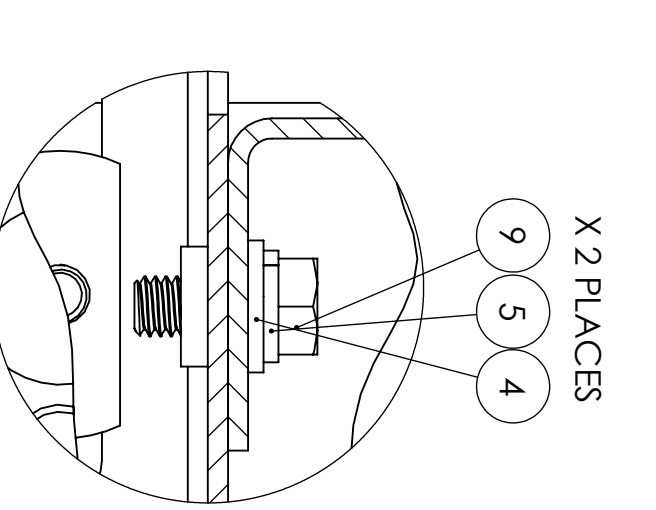
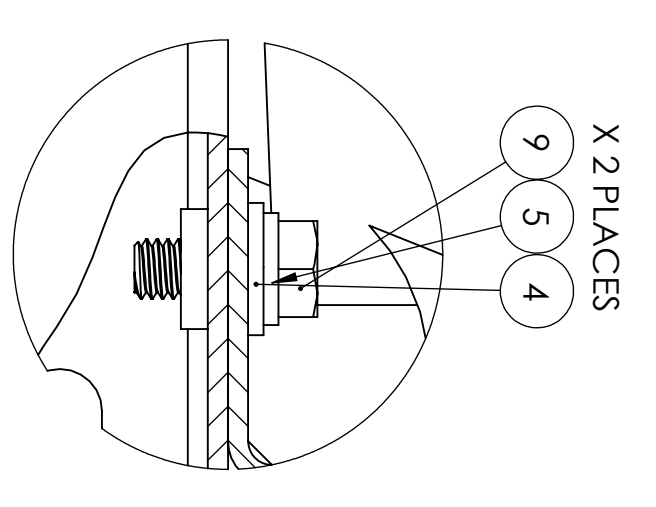
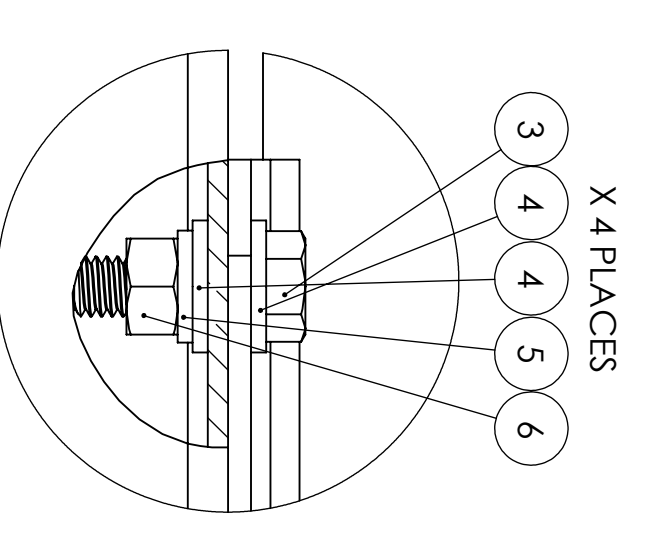
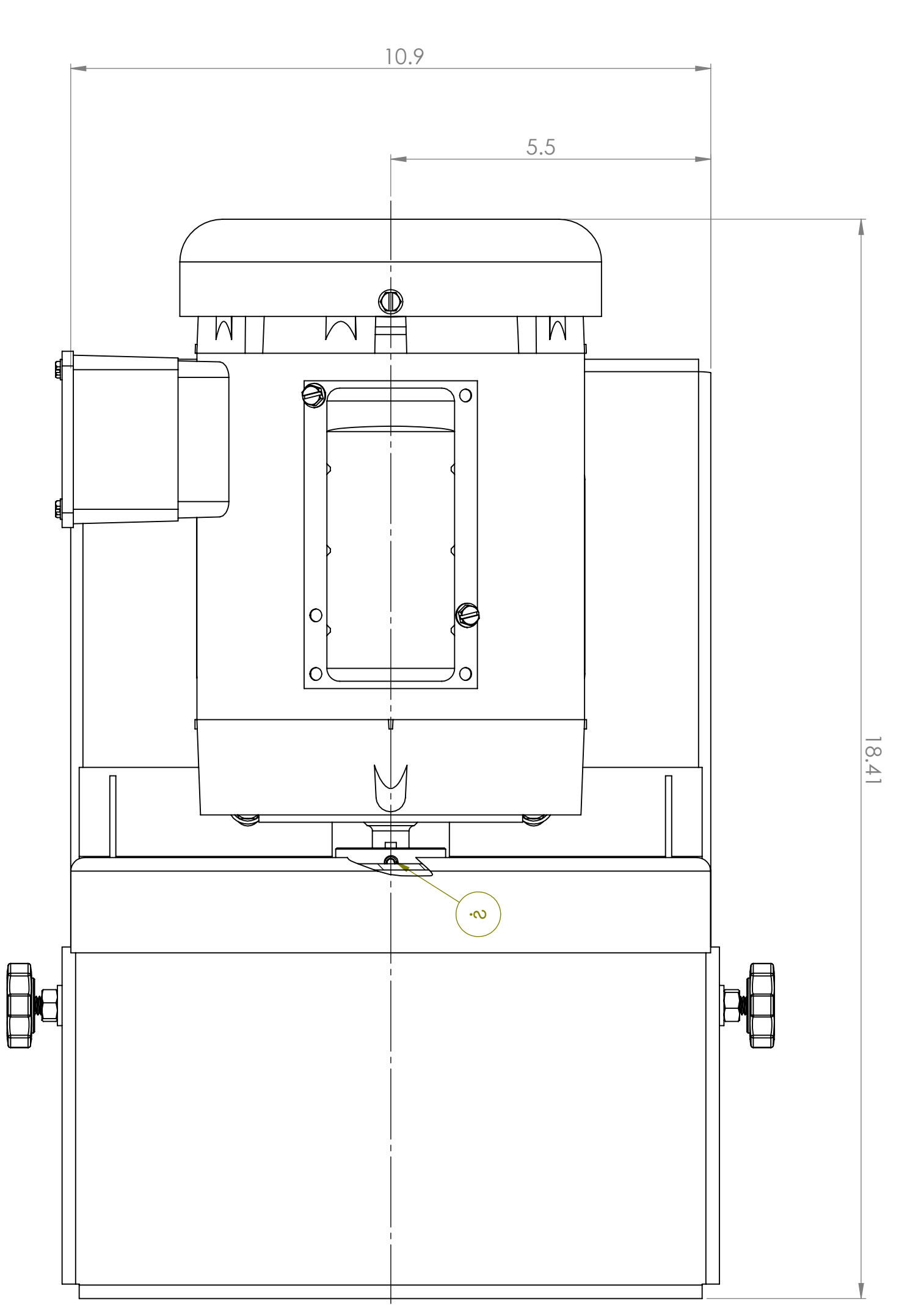

DETAIL A  
SCALE: 1:1  
MOTOR FASTENER DETAILS

DETAIL B  
SCALE: 1:1  
DISC GUARD FASTENER DETAILS

DETAIL C  
SCALE: 1:1  
WORK TABLE FASTENER DETAILS

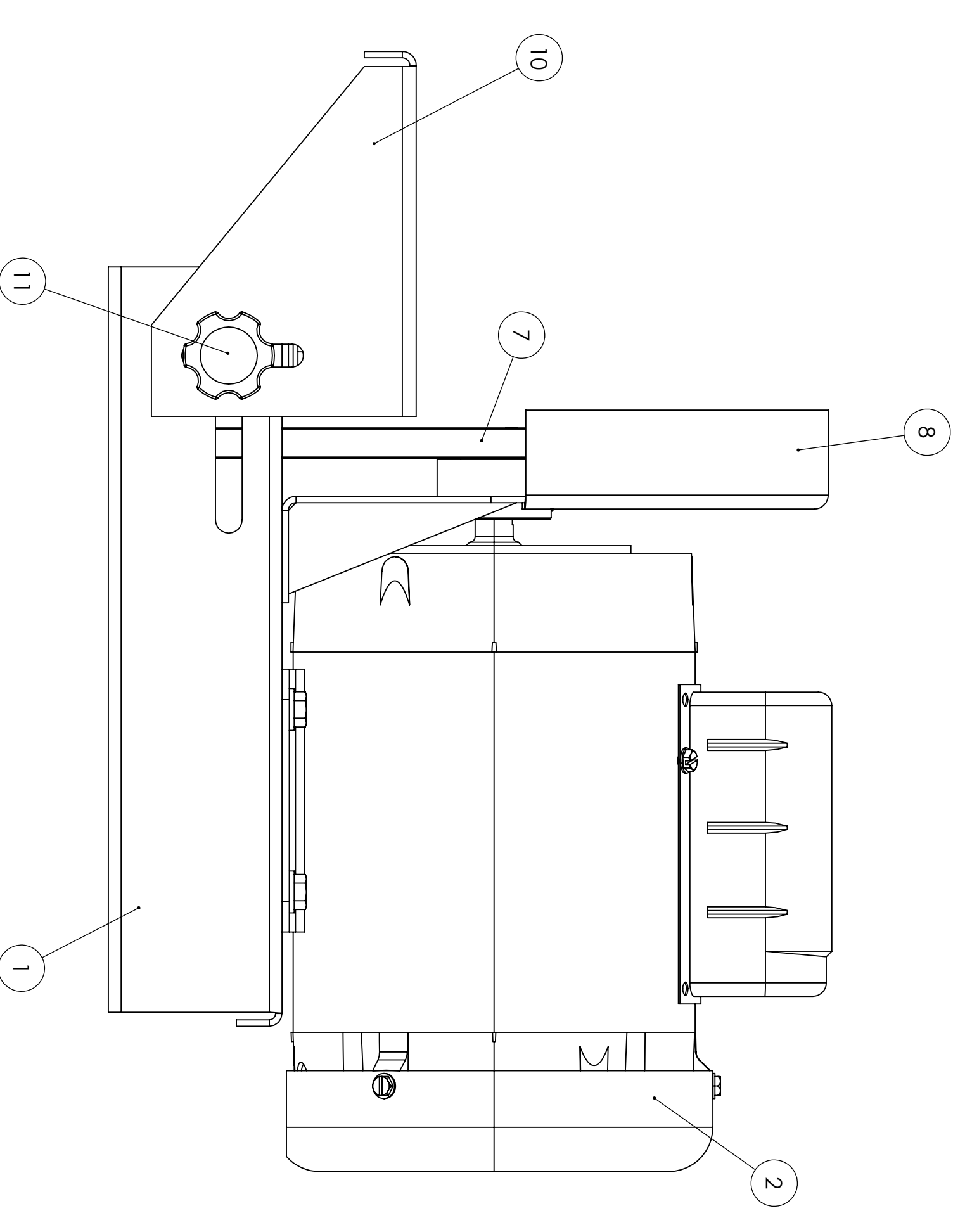
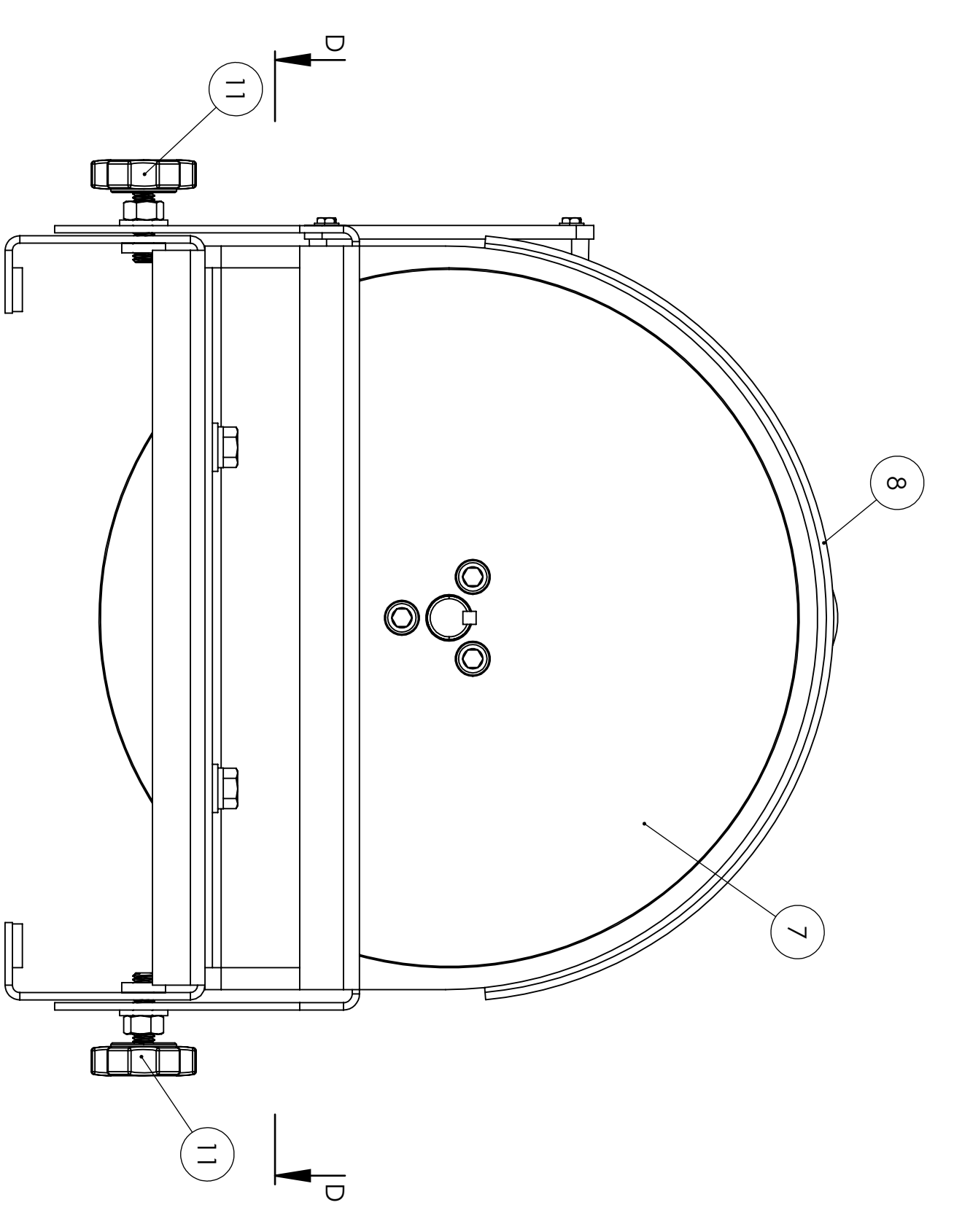
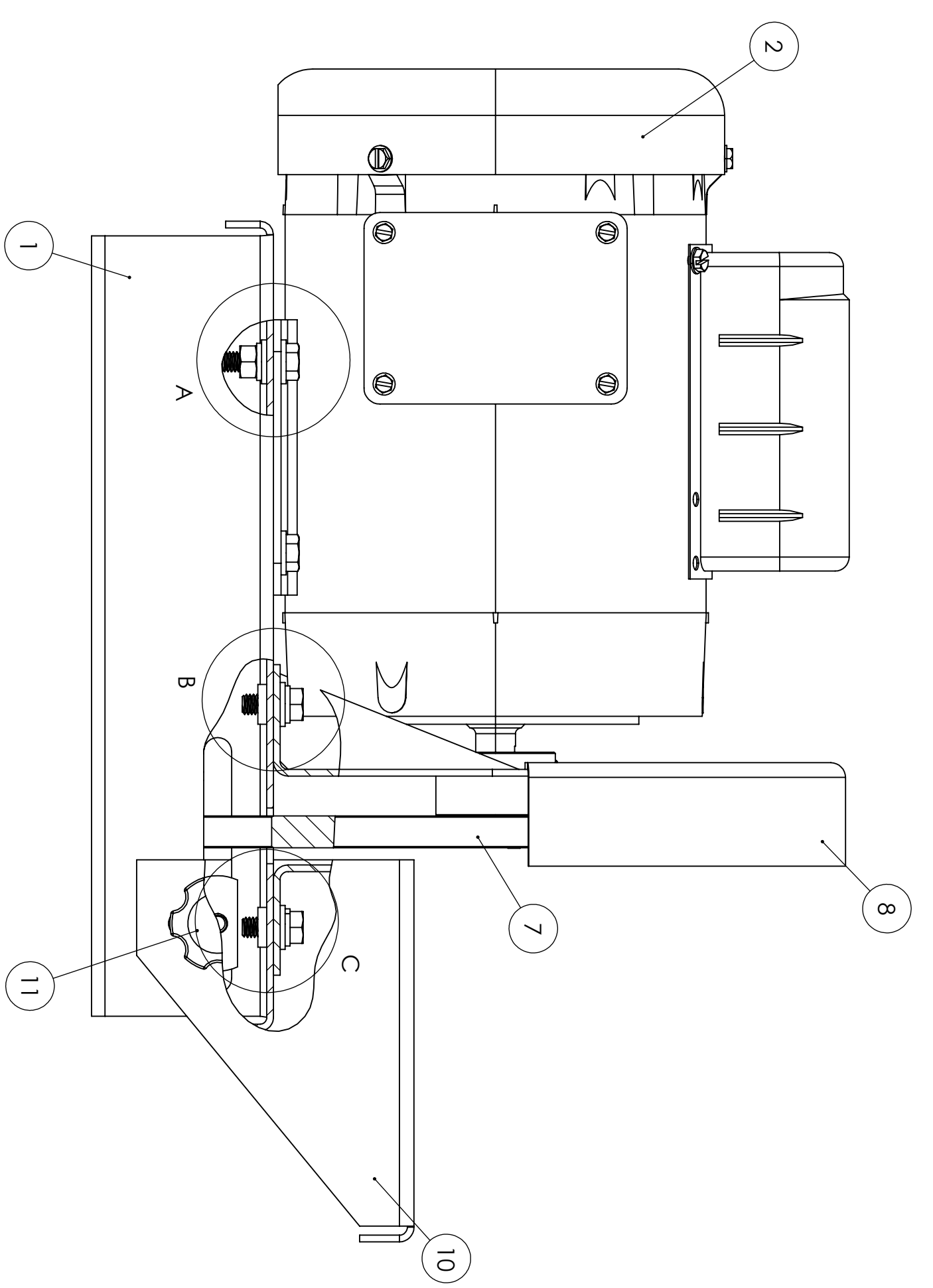
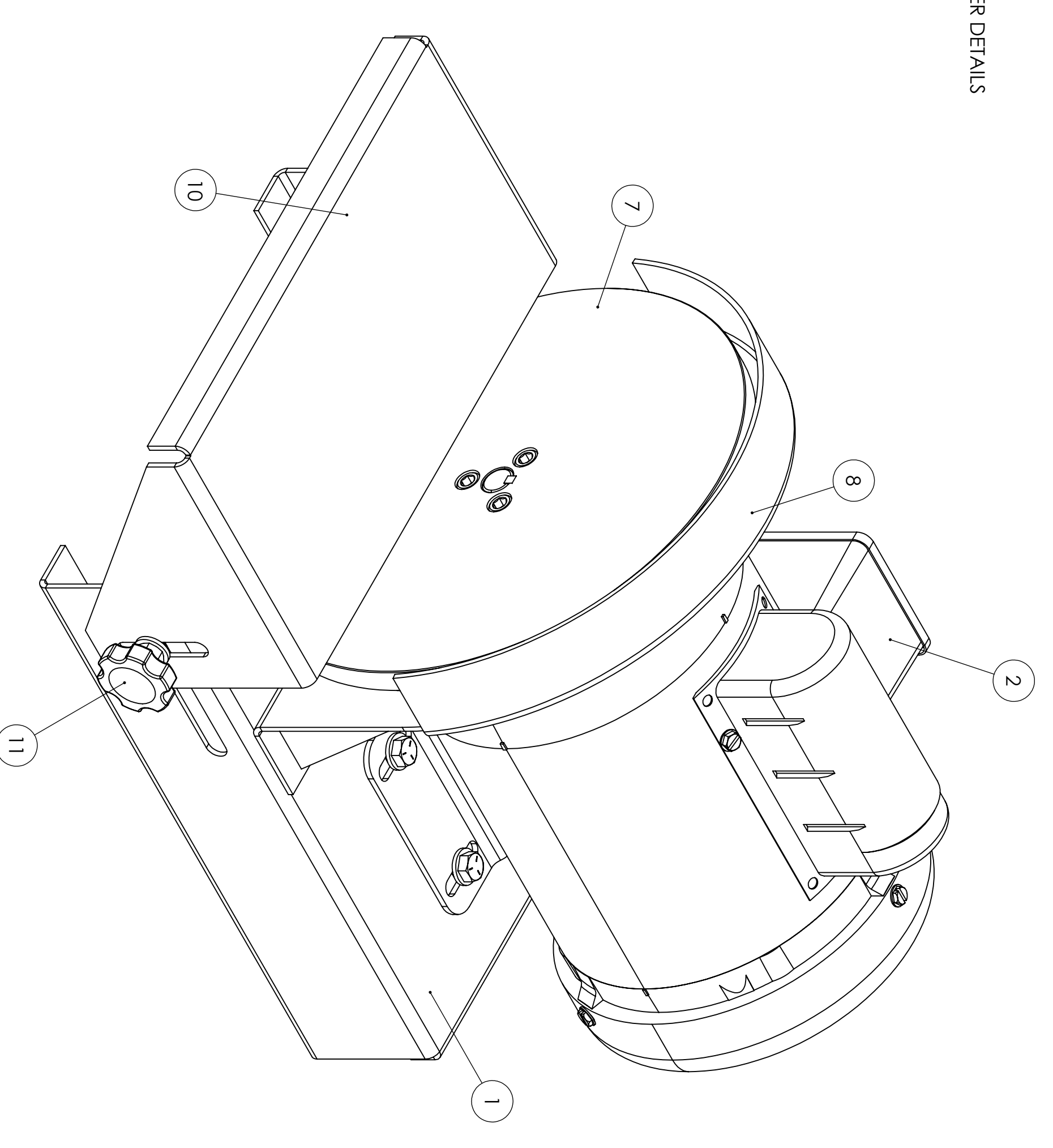
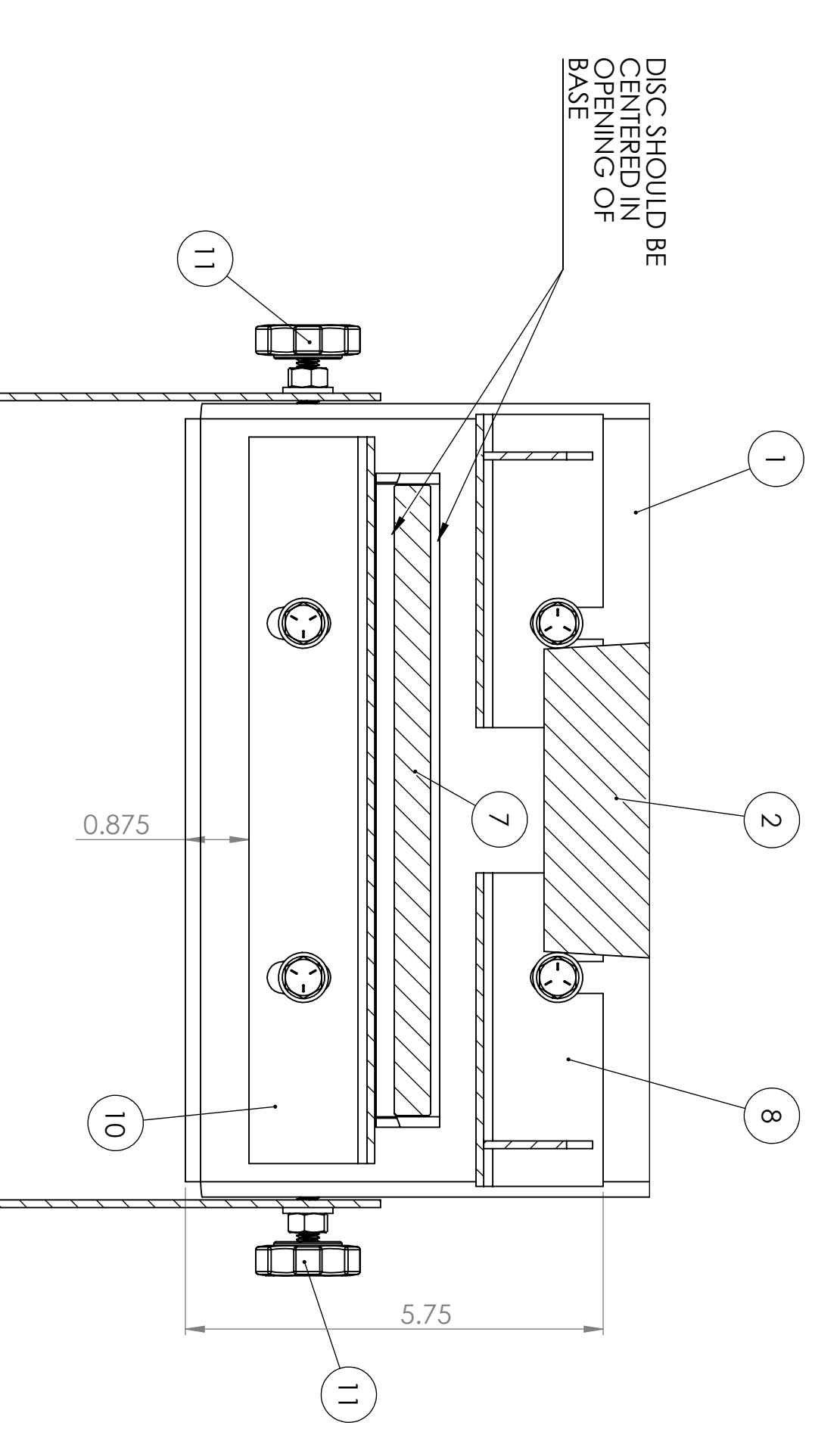

**KALAMAZOO**  
10 INCH DISC SANDER  
DS10

SCALE: 1/2 WEIGHT  
SHEET 0F 1

DATE	BY	CHKD	APP'D

REVISIONS:

NO.	DATE	DESCRIPTION
1		ISSUED FOR MANUFACTURE

ENGINEER: [Signature]  
DESIGNER: [Signature]  
CHECKER: [Signature]  
APPROVER: [Signature]