

SECTION D-D
SCALE 1:2

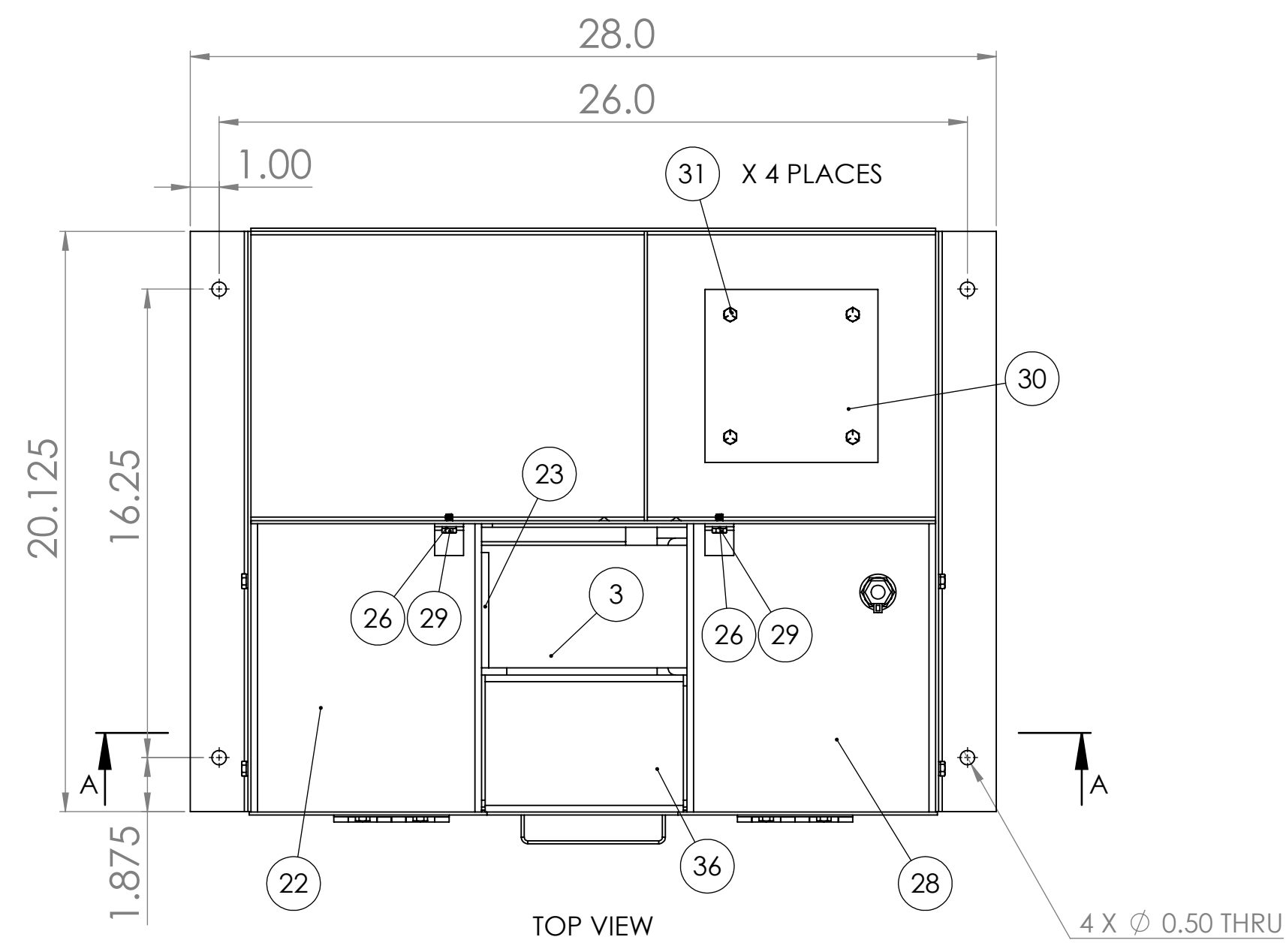

TOP VIEW

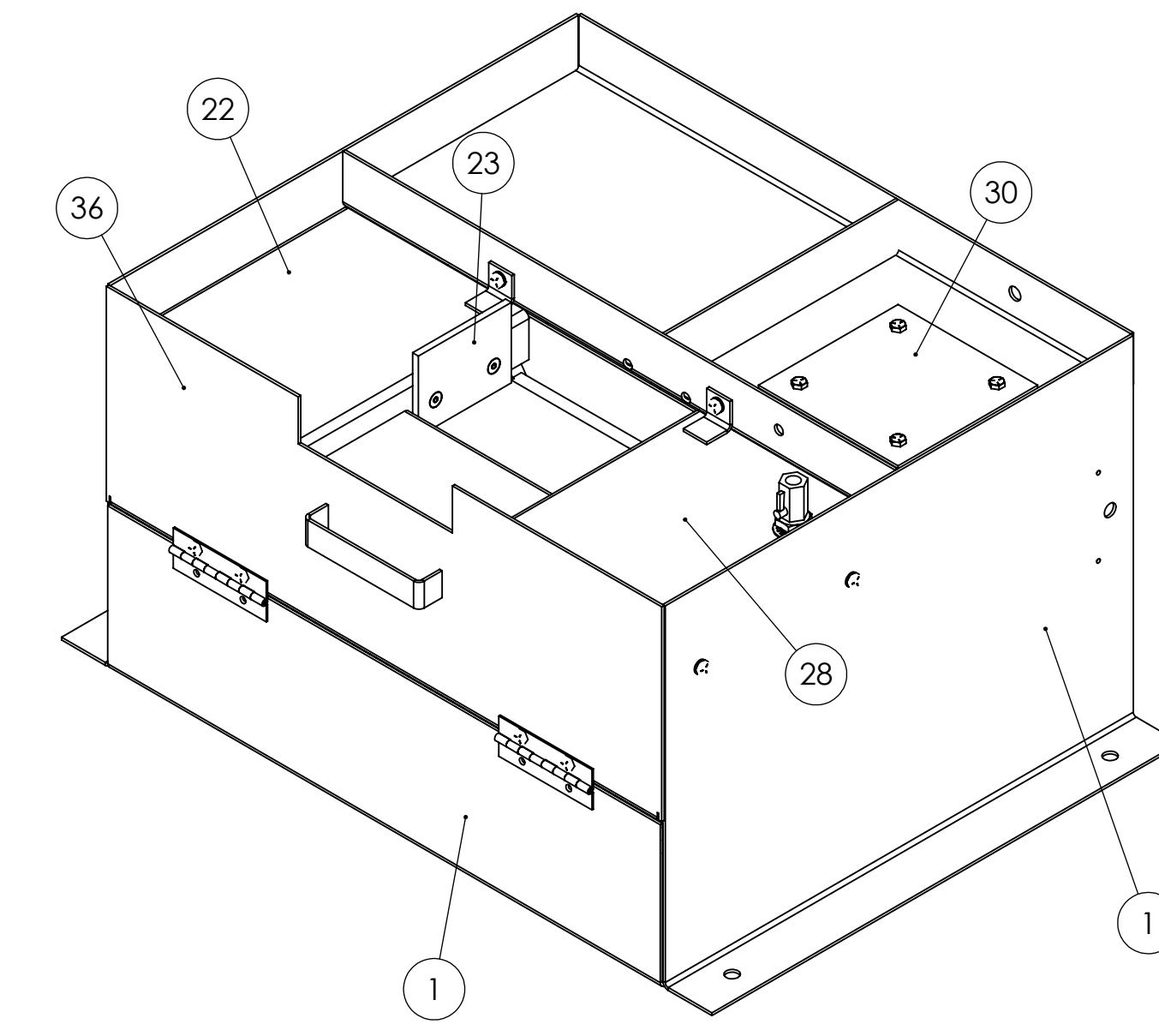

ITEM NO.	PART NUMBER	DESCRIPTION	QTY.
1	050-048	BASE FOR S4SWB	1
2	486-011	1/2H MOTOR FOR DS10, 2FSM-1725, S4S-1725, S4SWB	1
3	291-002	CAST IRON FRAME WITH PLATEN FOR S4, S4S, DS10-4	1
4	SHCA037012	3/8-16 X 3/4 SHCS	4
5	560-005	PULLEY, DRIVE (ALUMINUM) FOR S4, S4S, S460D	1
6	EERR0.5	EERR1/2 1/2" E RETAINING RING	2
7	UFWZ050	1/2 USS F/W Z	1
8	697-010	SPRING, TENSION FOR S4 SANDERS	1
9	HHC5031020	5/16-18 X 1-1/4 HHC GR 5 Z	1
10	FHN5031	5/16-18 FHN GR5 ZINC	1
11	697-011	TRACKING SPRING FOR S4	1
12	CRMZ010024	10-24 X 1-1/2 COMBO ROUND M/S Z	1
13	129-008	CAM FOR S4 TENSION SHAFT	1
14	RUD007008	#7 X 1/2 RD U-DRIVE SCREW Z	1
15	701-008	SPINDLE, IDLER FOR S4, S460 SANDERS	1
16	560-006	IDLER PULLEY S4 W BEARINGS FOR S4S AND S460	1
17	123-003	COLLAR FOR S4	1
18	SSKA010004	10-24 X 1/4 SOC SET KNURL PT	1
19	SSKA025006	1/4-20 X 3/8 SOC SET KNURL PT.	1
20	486-050	SUBMERSIBLE PUMP FOR KVF3 S4SWB1P939-0	1
21	BF22	BF22 HOSE BARB 1/4H X 1/4 FP	1
22	050-048A	S4SWB LOWER GUARD ASSEMBLY	1
23	050-048WORKTABLE	WORK TABLE FOR S4SWB	1
24	FSCA025016	1/4-20 X 1 FSHCS	2
25	UFWZ025	1/4 USS F/W Z	6
26	SLWZ025	1/4 SPLIT L/W Z	12
27	FHN5025	1/4-20 FHN GR5 Z	10
28	050-048B	S4SWB UPPER GUARD ASSEMBLY	1
29	HHC5025008	1/4-20 X 1/2 HHC GR5 Z	10
30	050-048-G	TOP DECK ACCESS PLATE FOR S4SWB BASE	1
31	HHC5025012	1/4-20 X 3/4 HHC GR5 Z	4
32	S35BZ0	S35BZ0 MINIATURE BALL VALVE 1/4 M X F	1
33	W05465	W05465 AIR BRAKE BULKHEAD COUPLING 1/4	1
34	TB3703	TB 3703 1 X 1/2 REDUCING WASHER	1
35	BN22	BN22 DX HOSE BARB 1/4H X 1/4 MNPT	1
36	050-048DOOR	S4SWB DOOR	1
37	960-002YA	S4, S4S, S4SWB YOKE AND TENSION SHAFT ASSEMBLY	1

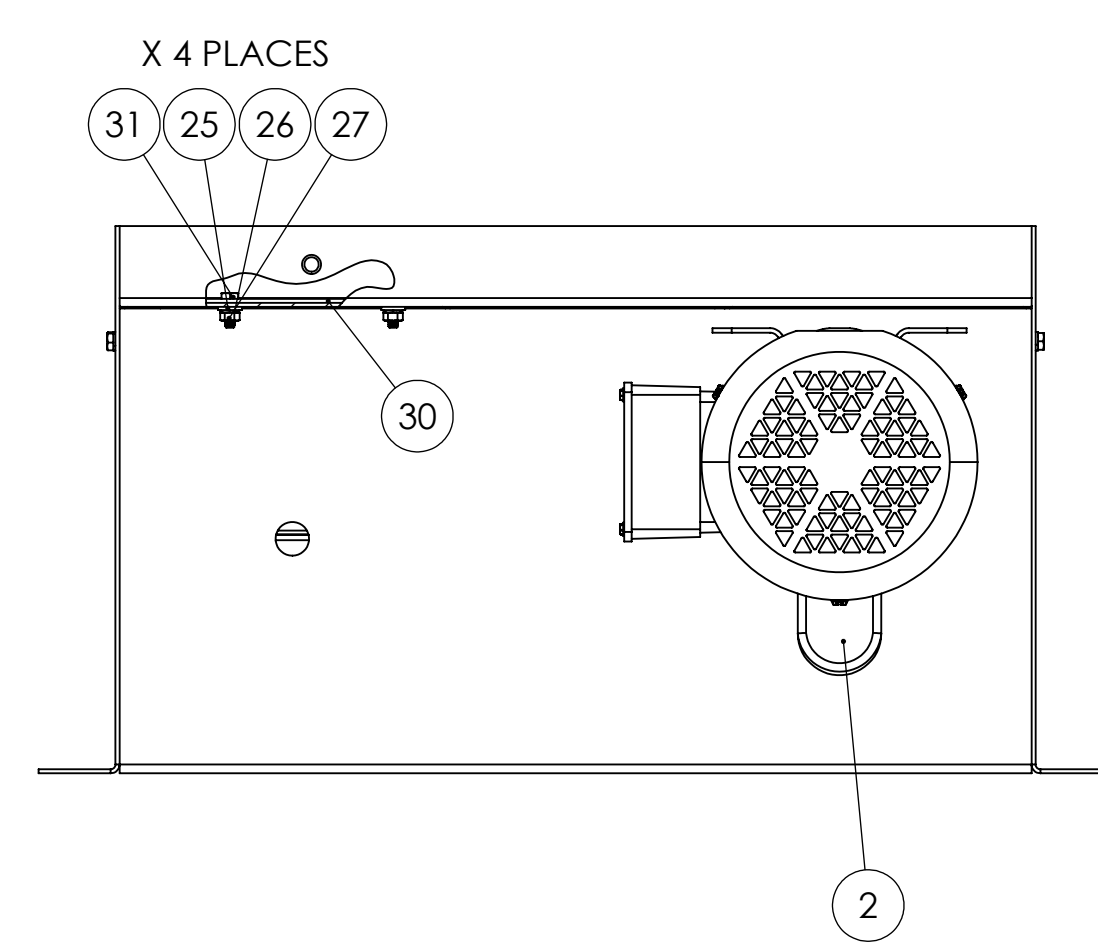

SECTION C-C
SCALE 1:2
DRIVE PULLEY INTERNAL VIEW

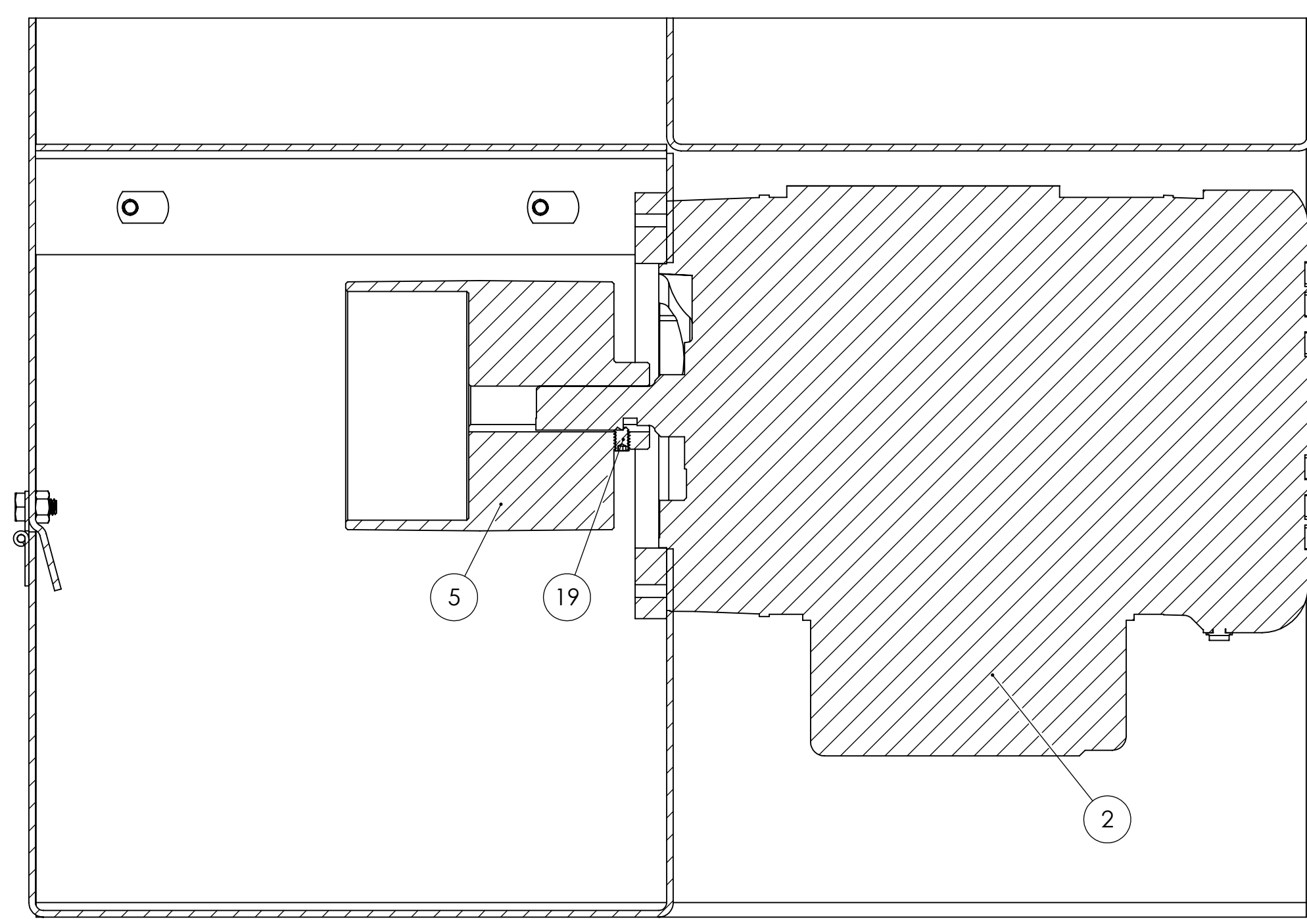
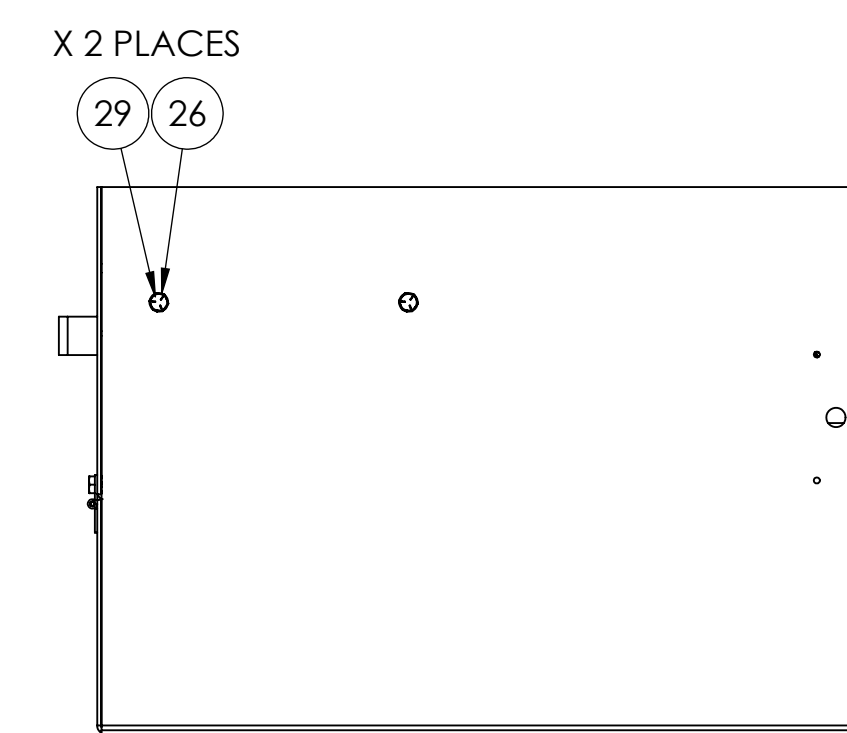
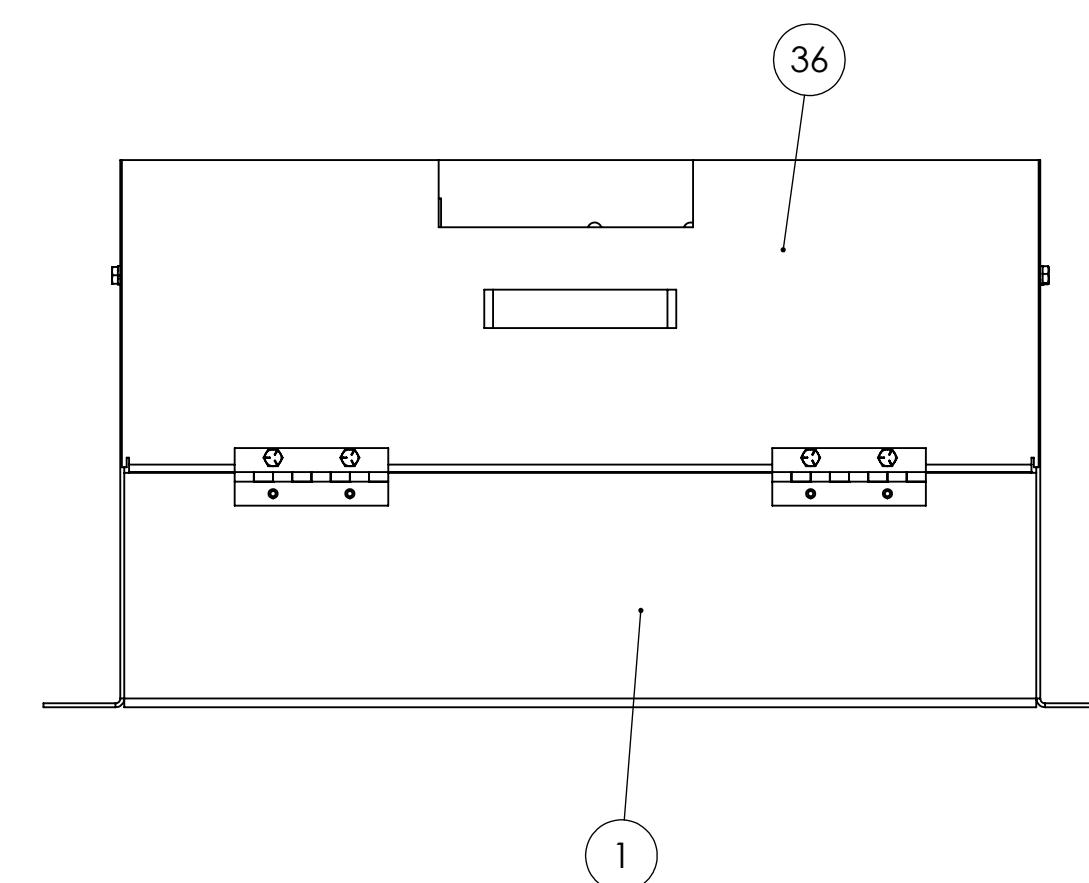
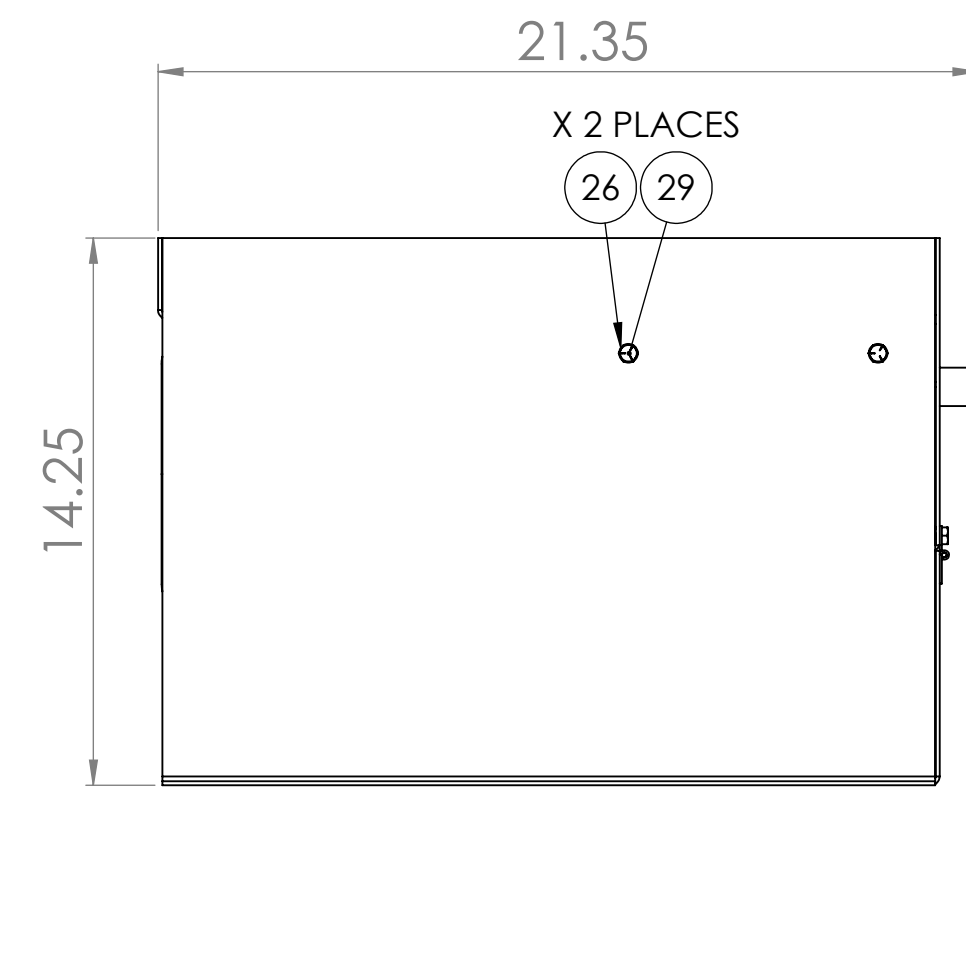

SECTION C-C
SCALE 1:2
DRIVE PULLEY INTERNAL VIEW

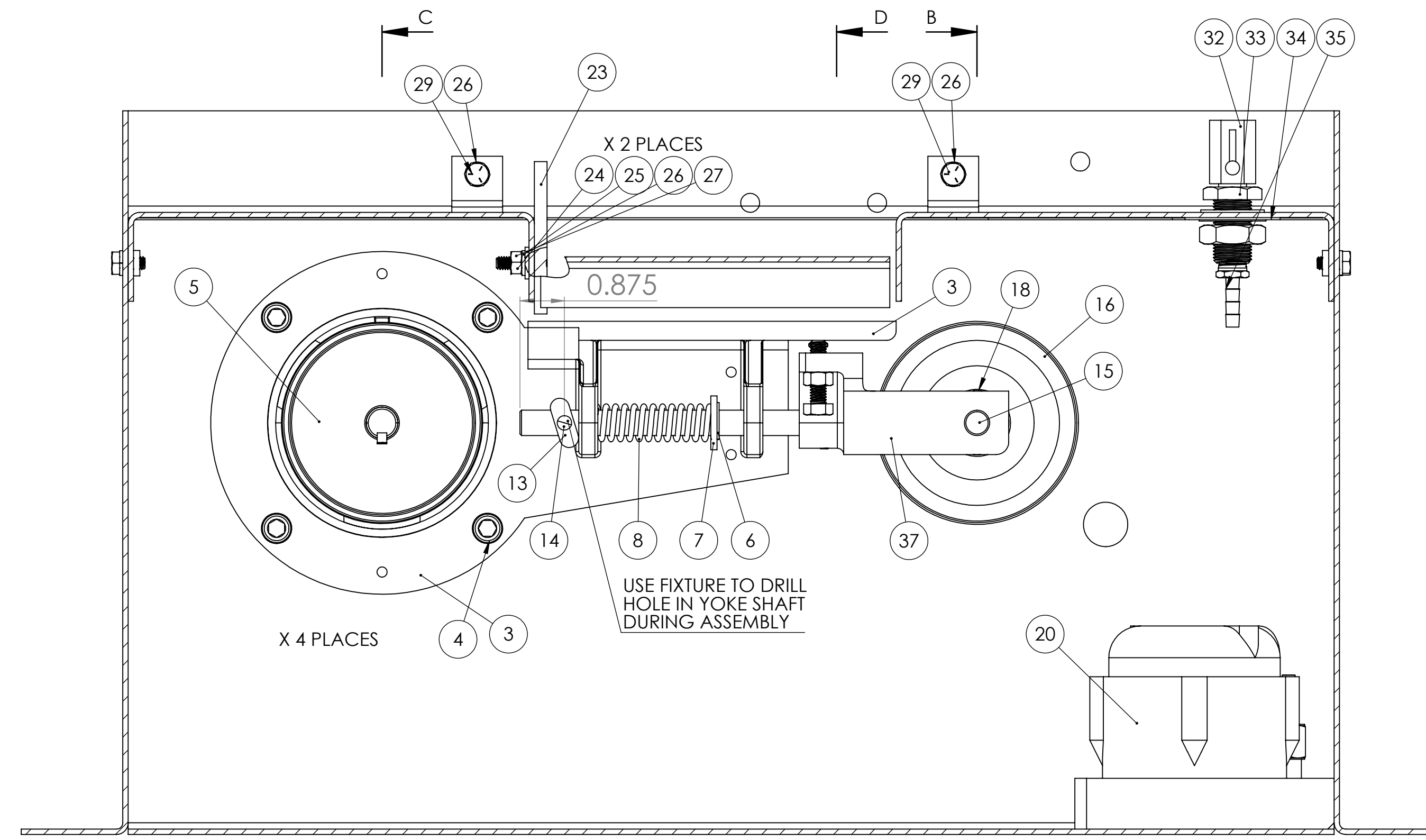

SECTION A-A
SCALE 1:2
MAIN INTERNAL VIEW

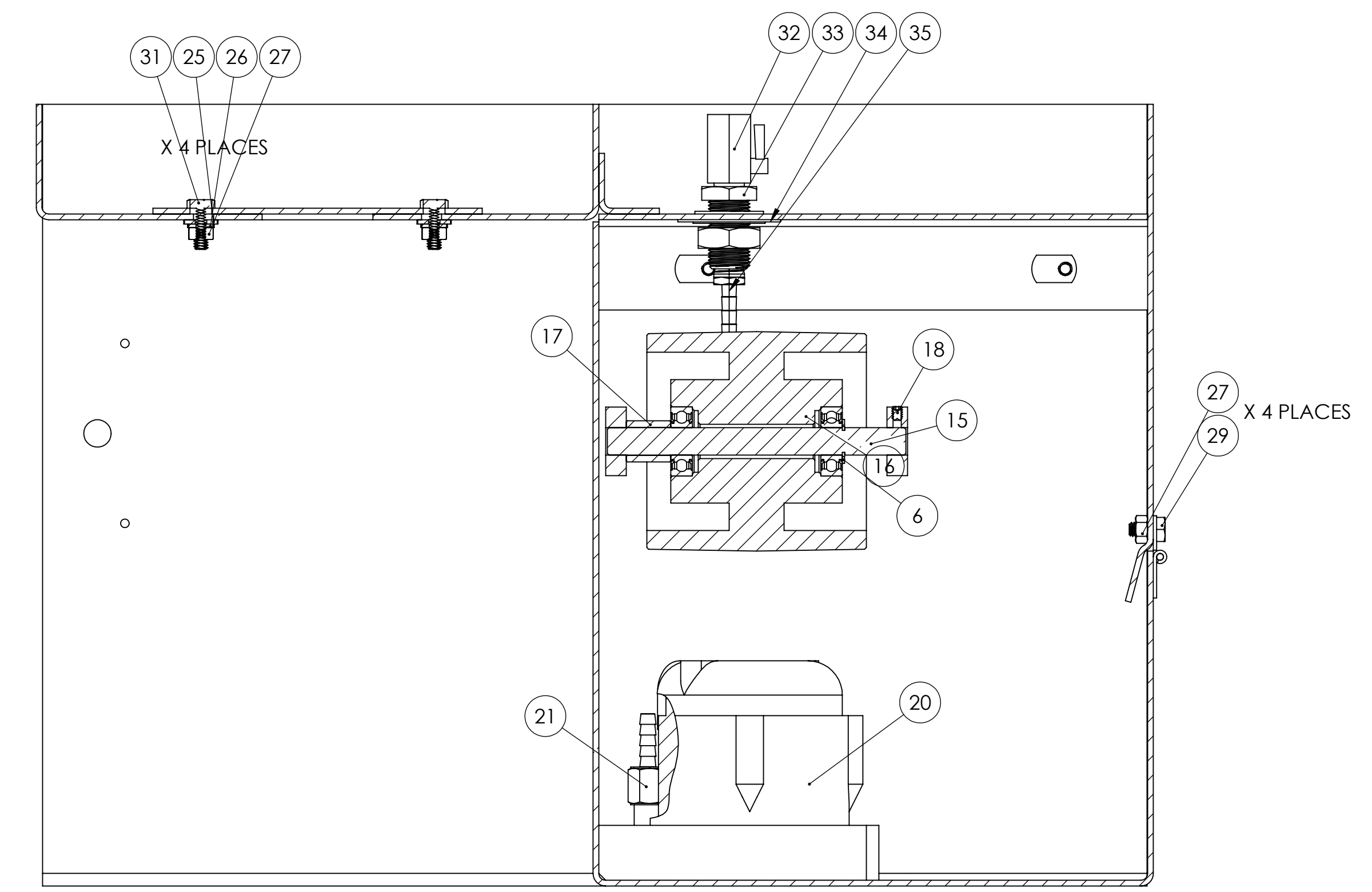

SECTION B-B
SCALE 1:2
IDLER PULLEY INTERNAL VIEW

UNLESS OTHERWISE SPECIFIED:
DIMENSIONS ARE IN INCHES
TOLERANCES:
FRACTIONS ± .005
DECIMALS ± .001
THREE PLACE DECIMAL ± .001
INTERFERENCE GEOMETRIC TOLERANCES PER ASME Y14.5

PROPRIETARY AND CONFIDENTIAL
THIS INFORMATION CONTAINED IN THIS DRAWING IS THE SOLE PROPERTY OF KALAMAZOO. IT IS TO BE KEPT IN CONFIDENCE AND NOT REPRODUCED OR TRANSMITTED IN ANY FORM OR BY ANY MEANS, ELECTRONIC OR MECHANICAL, INCLUDING PHOTOCOPYING, RECORDING, OR BY ANY INFORMATION STORAGE AND RETRIEVAL SYSTEM, WITHOUT THE WRITTEN PERMISSION OF KALAMAZOO.

DATE: _____
DRAWN BY: _____
CHECKED BY: _____
ENG APPR: _____
MFG APPR: _____
D.A. COMMENTS: _____

TITLE: MODEL S4SWB BENCHTOP BELT SANDER
SIZE: DWG. NO. E S4SWB
SCALE: 1:5 WEIGHT: _____
REV: _____
SHEET 1 OF 1