

KI KALAMAZOO
INDUSTRIES, INC.
KALAMAZOO, MI.



PH: (269) 382-2050

www.kalamazooind.com

**K7B-K8B ABRASIVE SAW
MANUAL**



MADE IN USA

WARNING!

TO REDUCE THE RISK OF FIRE OR SHOCK HAZARD, DO NOT EXPOSE THIS EQUIPMENT TO RAIN, ANY LIQUID OR MOISTURE.

INSPECTION

If these goods are damaged in transit, the **DELIVERING TRANSPORTATION COMPANY** is required by law to make notation of damages on the freight bill. If in your opinion, there may be concealed damage, they are required to make an inspection after goods are unpacked. Transportation rates are made in proportion to damage. Therefore, the carrier and **NOT** the shipper should be charged with any loss or damage. Any claim should be filed with the delivering Transportation Company. **PLEASE DO NOT RETURN GOODS TO US WITHOUT OUR RGA NUMBER AND SHIPPING INSTRUCTIONS.**

Electrical: CAUTION: Voltage changes require wiring changes at drive motor. **WARRANTY DOES NOT COVER** unauthorized wiring changes/failures. **Consult an electrician an electrician if your not familiar with electrics.**

K7B SETUP

- BEFORE STARTING OR CONNECTING ELECTRICAL VERIFY THE PHASE AND VOLTAGE OF THE UNIT.
- BE SURE MACHINE IS BALANCED CORRECTLY SO IT WILL TIP OVER.
- TO GUARD AGAINST CONCEALED DAMAGE, STAND CLEAR AND OBSERVE UNIT FOR THE FIRST FEW MINUTES OF OPERATION. GUARDS MUST NEVER BE REMOVED.
- BEFORE INSTALLING THE ABRASIVE WHEEL CONFIRM THAT THE CUTOFF WHEEL IS DESIGNED TO RUN AT 4800 SFPM (MOS). YOU CAN FIND THIS INFORMATION DIRECTLY ON THE THE SIDE OF YOUR CUTOFF WHEEL. IT

ABRASIVE SAW SAFETY

- NEVER REMOVE SAFETY GUARDS FROM MACHINE. DISCONNECT MACHINE FROM POWER SOURCE BEFORE MAKING ANY MACHINE ADJUSTMENTS.
- DO NOT USE AROUND FLAMMABLE MATERIALS OR LIQUIDS.
- MACHINES SHOULD BE OPERATED IN VENTILATED AREAS.
- ALWAYS WEAR SAFETY GLASSES OR A FULL FACE SHIELD FOR PROTECTION.
- DO NOT USE TOOTHED BLADE WITH THIS SAW AND DO NOT ATTEMPT TO USE STEEL BLADES ON THIS SAW.
- KEEP HANDS CLEAR OF THE CUTTING AREA.
- DO NOT WEAR GLOVES OR LOOSE FITTING CLOTHES WHEN OPERATING THIS MACHINE.
- ALWAYS KEEP HAIR TIED BACK OR COVERED.
- ALWAYS KEEP FLANGES CLEAN AND TIGHT AGAINST CUTTING WHEEL.
- MANUALLY TIGHTEN AND LOOSE SPINDLE NUT.
- DO NOT USE IMPACTED GUN TO LOOSEN OR TIGHTEN SPINDLE NUT.
- ALWAYS KEEP WHEEL GUARD IN THE DOWN POSITION.
- BE SURE WORK PIECE IS CLAMPED SECURELY IN VISE BEFORE CUTTING.

WARNING!!!!

IMPROPER USE MAY CAUSE BREAKAGE AND SERIOUS INJURY.

DO

1. **DO** always handle and store wheels in the vertical position.
2. **DO** visually inspect all wheels before mounting for possible damage.
3. **DO** check machine speed against the established maximum safe operating speed marked on the wheel.
4. **DO** check mounting flanges for equal and correct diameter.
5. **DO** use mounting blotters when supplied with wheels.
6. **DO** always use a safety guard covering a least one-half of the abrasive wheel.
7. **DO** allow newly mounted wheels to run at operating speed, with guard in place, for at least one minute before cutting.
8. **DO** always wear safety glasses or some type of eye protection when cutting.
9. **DO** tie back hair.

DON'T

1. **DON'T** use a cracked wheel or one that has been dropped or has become damaged.
2. **DON'T** force a wheel onto the machine or alter the size of the mounting hole if wheel won't fir the machine.
3. **DON'T** ever exceed maximum operating speed established for the wheel.
4. **DON'T** use mounting flanges on which the bearing surfaces are not clean, flat and free of burrs.
5. **DON'T** tighten the spindle nut excessively.
6. **DON'T** start the machine until the wheel guard is in place.
7. **DON'T** jam work into wheel.
8. **DON'T** force cutting so that motor slows noticeable or work gets hot.
9. **DON'T** wear gloves and or have loose clothing when operating machine.
10. **DON'T** use tooth blade on saw.

BASIC OPERATION

1. Be certain correct wiring is matched to motor.
2. Always keep flanges clean and tight against the abrasive wheel.
3. Be certain work piece is securely clamped in the vise. Any movement in the work piece during cutting will result in broken abrasive cutoff blades.
4. Down stop screw located on saw base (#31) under the saw arm (#2) must be adjusted so the abrasive wheel does not cut into the saw base. Adjust the screw up when installing a new wheel so as not to allow the wheel to cut into the saw base. Keep adjusting the screw down as the wheel wears so you can cut thru the work piece.
5. Keep the blade guard in the down position at all times. Guarding is designed for abrasive blades only. **DO NOT USE STEEL TOOTHED BLADES!!! GUARDING IS NOT DESIGNED FOR STEEL TOOTHED BLADES PER OSHA AND ANSI STANDARDS.**
6. Select the correct abrasive wheel for the material. Every abrasive wheel performs differently. With low HP motors a free cutting wheel like the Kalamazoo Industries #KAB7N non-reinforce wheels give free cutting on most materials. Good cuts are bright like the material and not burned or discolored. If burning occurs then select another grade of abrasive wheel. Consult your dealer or wheel manufacturer for wheel grade selection. It may take many test cuts on different wheels to obtain the wheel that works the best for your material. Use enough cutting force to make the wheel wear or "break down".
7. **Saw spindle speed is set at 4,700 SFPM select cutoff wheel that's designed to run at 4,700 SFPM or greater. Using cutoff wheel's designed to run under 4,700 SPM could cause wheel failure and could cause serious injury to operator. Contact the wheel manufacturer or dealer for the correct wheel.**
8. Always follow safety procedures. Wear safety glasses, never wear gloves or loose fitting clothing that can get caught in the moving parts and tie back loose hair. Always keep hands out of sawing area when cutting. See attached safety sheet.
9. V-belts will stretch with use over time. Keep v-belts tight with 1/2" of "squeeze". Use a v-belt tensioner to tighten v-belt belt. Keep both faces of spindle and motor pulley aligned in the same plan with a straight edge. Check motor and spindle pulleys set prior to operating the machine.

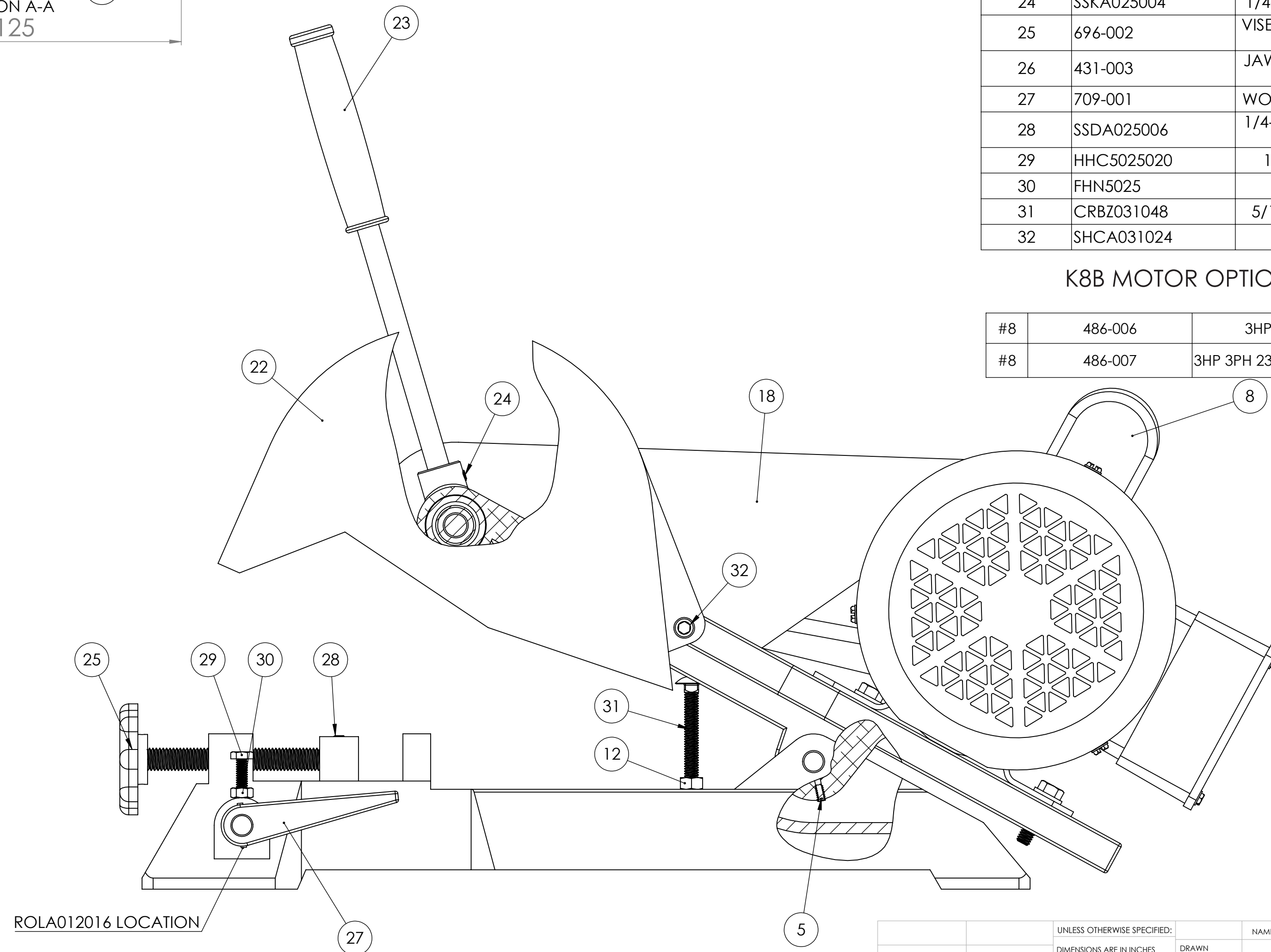
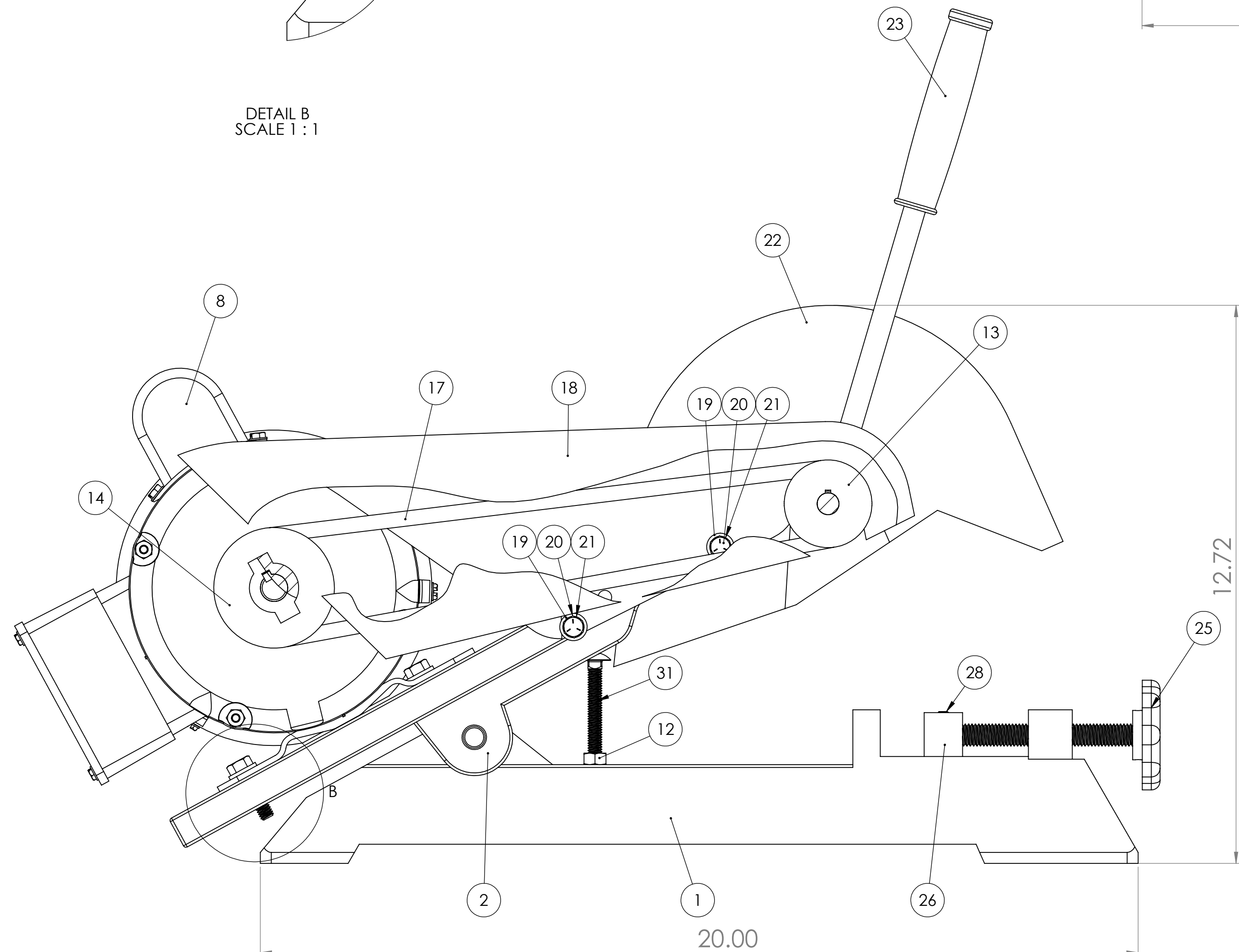
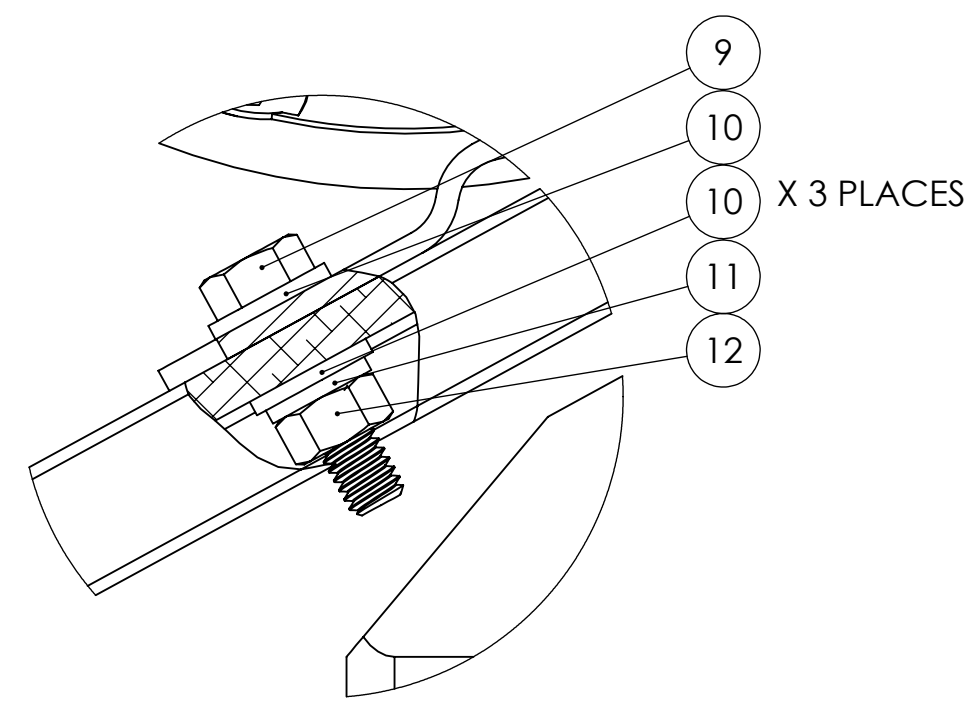
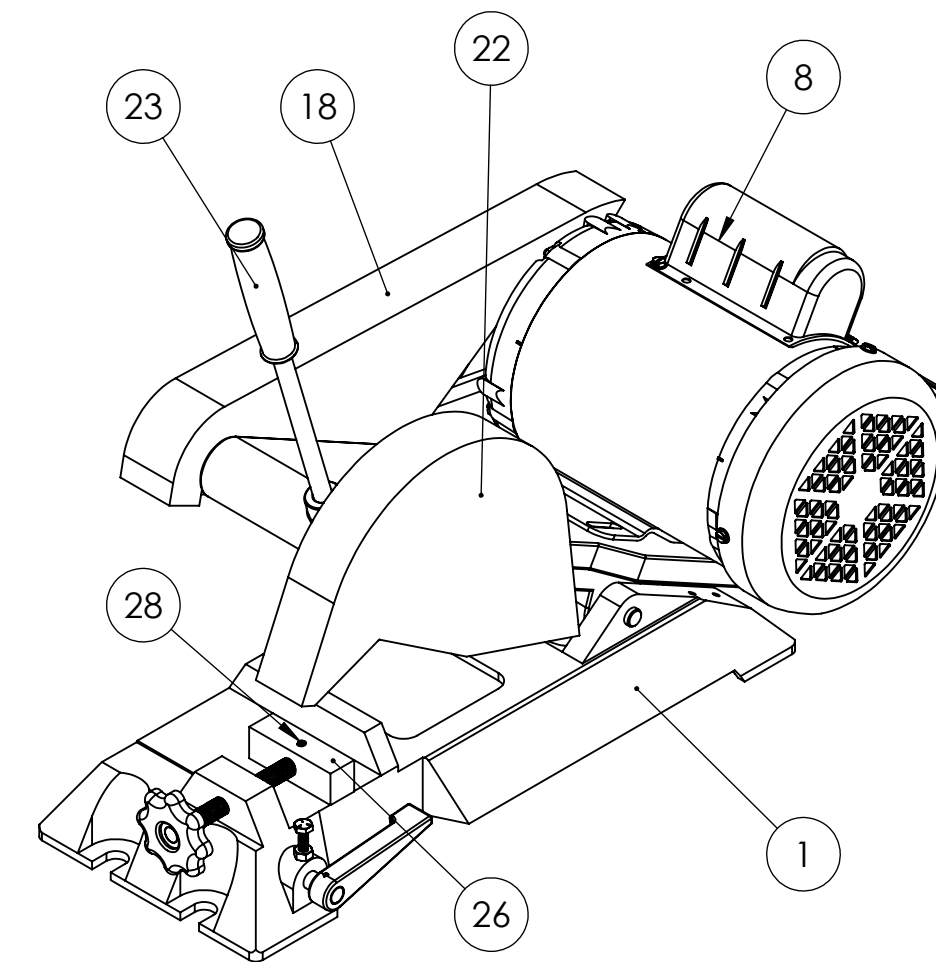
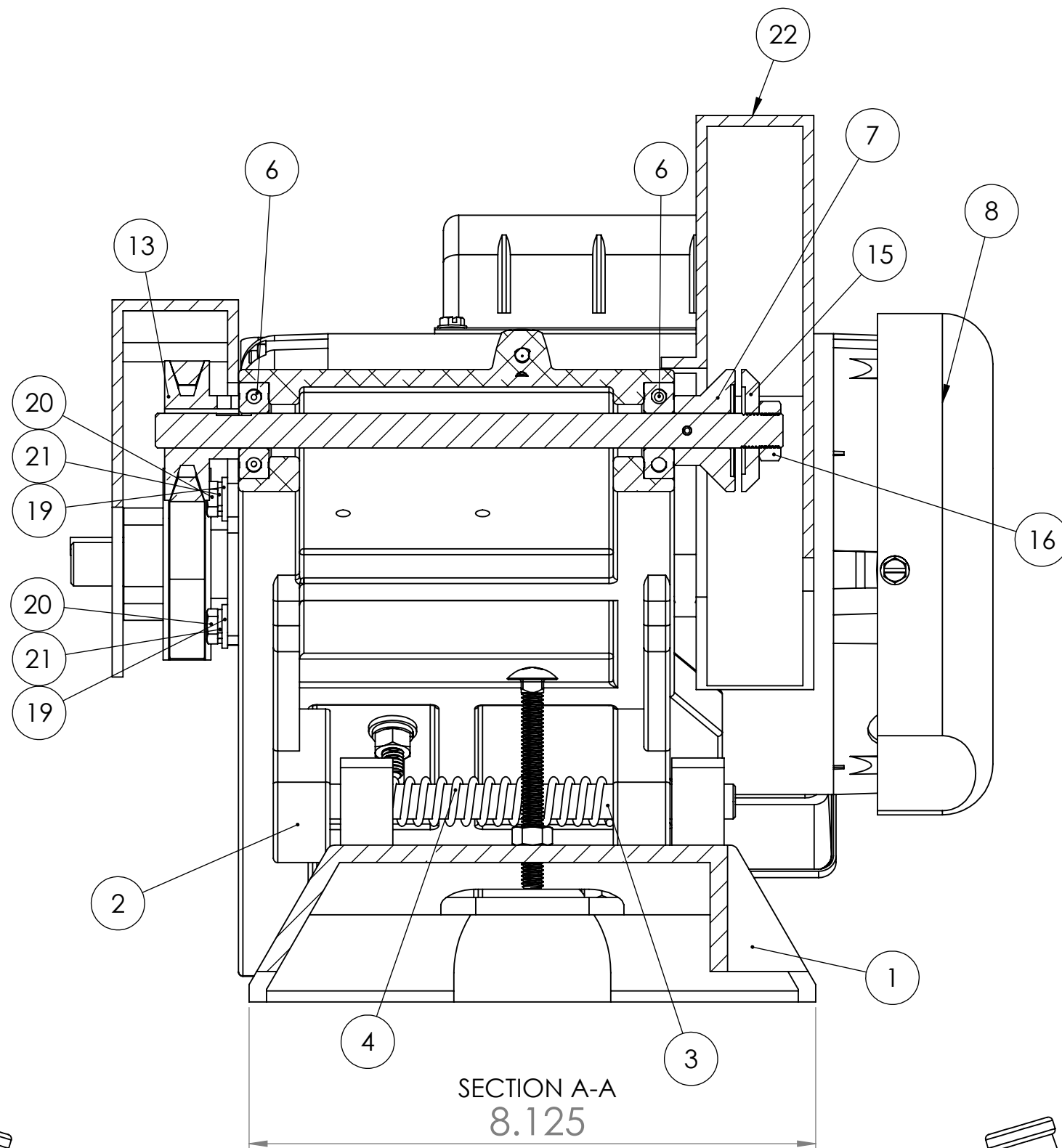
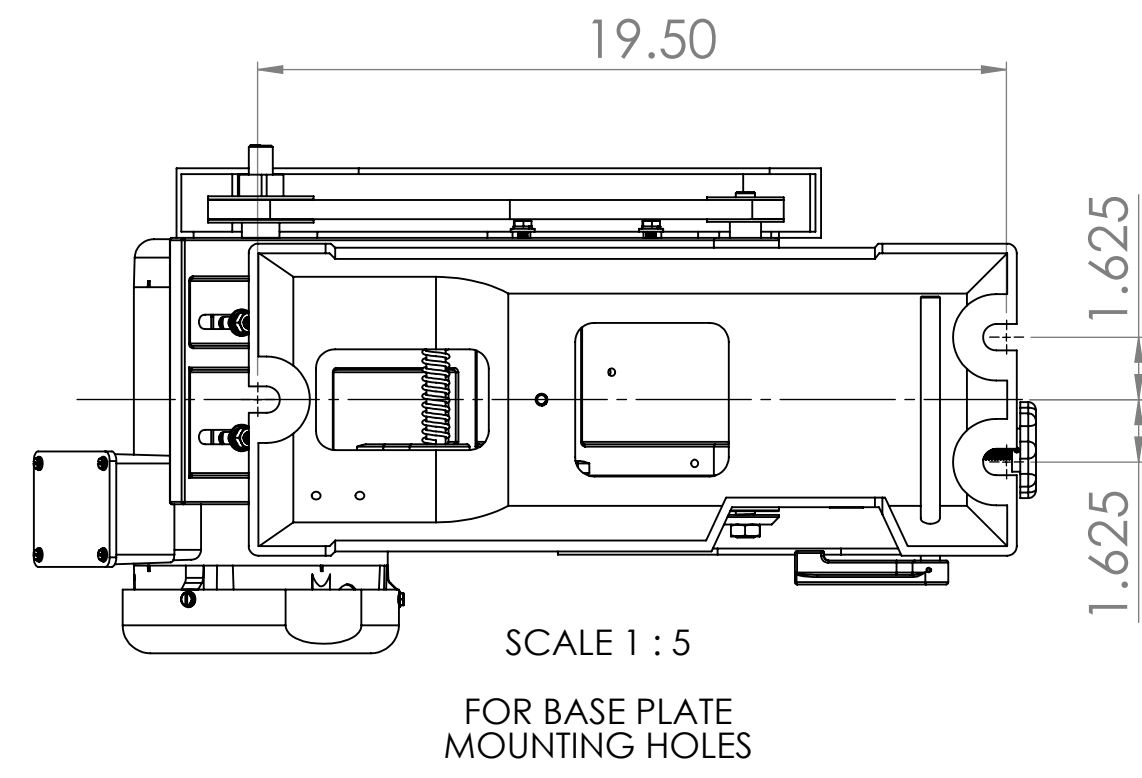

ITEM NO.	PART NUMBER	DESCRIPTION	QTY.
1	050-001	K7B- K8B SAW BASE	1
2	002-001	ALUMINUM SAW ARM FOR K7B, K8B, K10B (TAKES NEW 6202-2RS-1/2 BEARINGS)	1
3	562-004	TRUNNION PIN FOR K7B, K8B, K10B	1
4	697-013	TENSION SPRING FOR 2FS, 2FS72, 2FSM, BG142, 2FS72M, K12-14B	1
5	SHCA010006	10-24 X 3/8 SHCS CUP POINT	1
6	044-012	BEARING FOR K7B, K8B, 6202-2RS-1/2	2
7	701-012	SPINDLE WITH TIGHT FLANGE FOR K7B-K8B	1
8	486-002A	1HP, 1PH, 3450RPM, 60HZ, 56F, 115/230 FOR K7B	1
9	HHC5031020	5/16-18 X 1-1/4 HHCS GR 5 Z	3
10	UFWZ031	5/16 USS F/W Z	6
11	SLWZ031	5/16 SPLIT L/W Z	3
12	FHN5031	5/16-18 FHN GR5 ZINC	4
13	560-003	1/2" SPINDLE PULLEY (200A5) FOR K7B-K8B	1
14	560-004	5/8 MOTOR PULLEY (ALUMINIUM/275A6) FOR K7B, K8B, 2FS, 2FSM(OLD STYLE)	1
15	292-002	LOOSE FLANGE FOR K7B, K8B	1
16	FJNZ051	1/2-20 F H JAM NUT Z	1
17	051-001	4L-330 V-BELT FOR K7B, K8B, 2FS AND 2FS72M (OLD STYLE)	1
18	342-002	BELT GUARD FOR K7B AND K8B	1
19	UFWZ025	1/4 USS F/W Z	2
20	HHC5025012	1/4-20 X 3/4 HHCS GR5 Z	2
21	SLWZ025	1/4 SPLIT L/W Z	2
22	342-001	WHEEL GUARD FOR K7B AND K8B	1
23	381-003	HANDLE W GRIP FOR K7B, K8B, K10B SAWS	1
24	SSKA025004	1/4-20 X 1/4 SOC SET KNURL PT.	1
25	696-002	WISE SCREW ASSEMBLY FOR K7B, K8B	1
26	431-003	JAW, VISE BLOCK FOR K7B AND K8B SAWS	1
27	709-001	WORK STOP FOR K7B, K8B SAWS	1
28	SSDA025006	1/4-20 X 3/8 SOC SET FULL DOG PT	1
29	HHC5025020	1/4-20 X 1-1/4 HHCS GR5 Z	1
30	FHN5025	1/4-20 FHN GR5 Z	1
31	CRBZ031048	5/16-18 X 3 CARRIAGE BOLT Z	1
32	SHCA031024	5/16-18 X 1-1/2 SHCS	1

K8B MOTOR OPTIONS

#8	486-006	3HP 1PH 115V
#8	486-007	3HP 3PH 230V AND OR 460V

PROPRIETARY AND CONFIDENTIAL
 THE INFORMATION CONTAINED IN THIS DRAWING IS THE SOLE PROPERTY OF KALAMAZOO INDUSTRIES, INC. ANY REPRODUCTION IN PART OR AS A WHOLE WITHOUT THE WRITTEN PERMISSION OF KALAMAZOO INDUSTRIES, INC. IS PROHIBITED.

UNLESS OTHERWISE SPECIFIED:		NAME		DATE	
DIMENSIONS ARE IN INCHES	DRAWN				
FRACTIONAL ±	CHECKED				
ANGULAR ±	ENG APPR.				
TWO PLACE DECIMAL ±	MFG APPR.				
THREE PLACE DECIMAL ±	Q.A.				
INTERPRET GEOMETRIC TOLERANCING PER: MATERIAL	COMMENTS:				
FINISH					
NEXT ASSY	USED ON				
APPLICATION	DO NOT SCALE DRAWING				

KALAMAZOO INDUSTRIES, INC.

TITLE: **K7B-K8B SAW ASSEMBLY**

SIZE DWG. NO. **D K7B-K8B** REV

SCALE: 1:2 WEIGHT: SHEET 1 OF 1

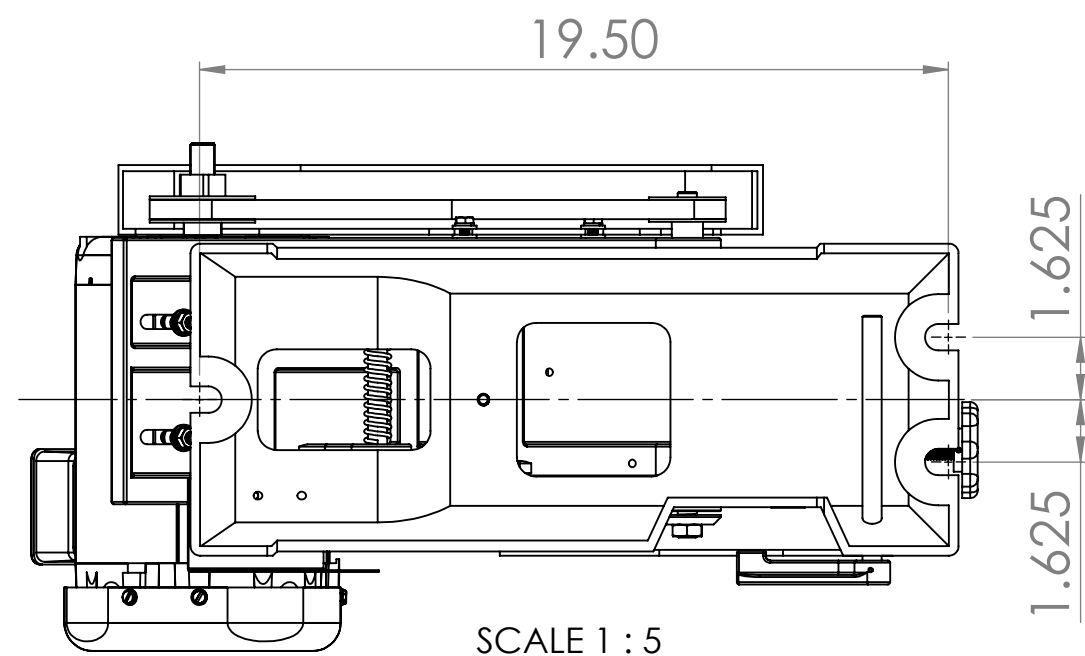

SCALE 1 : 5
FOR BASE PLATE
MOUNTING HOLES

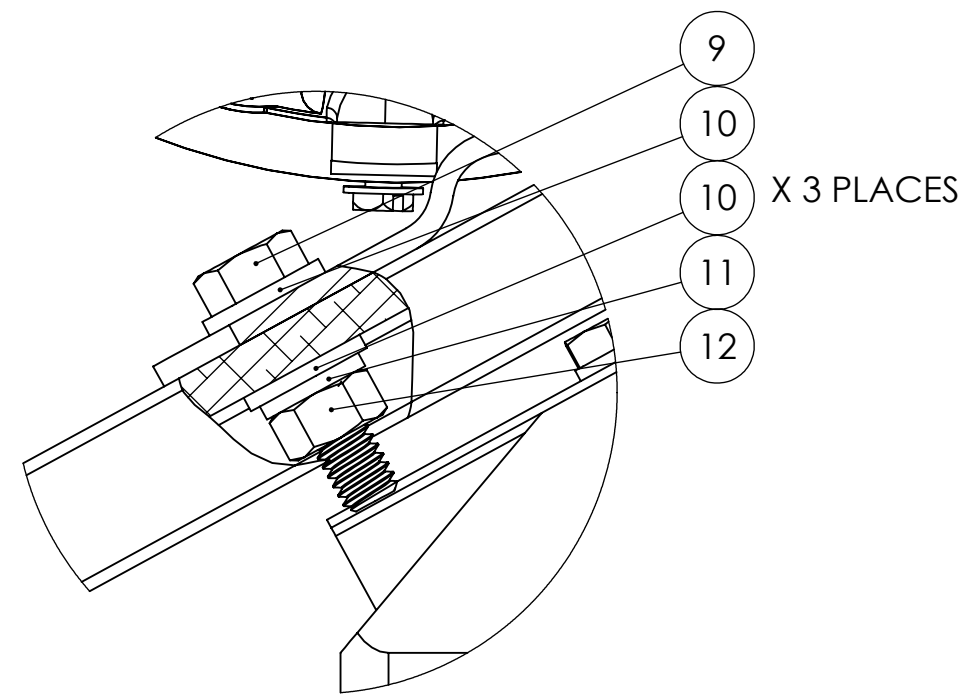

DETAIL B
SCALE 1 : 1

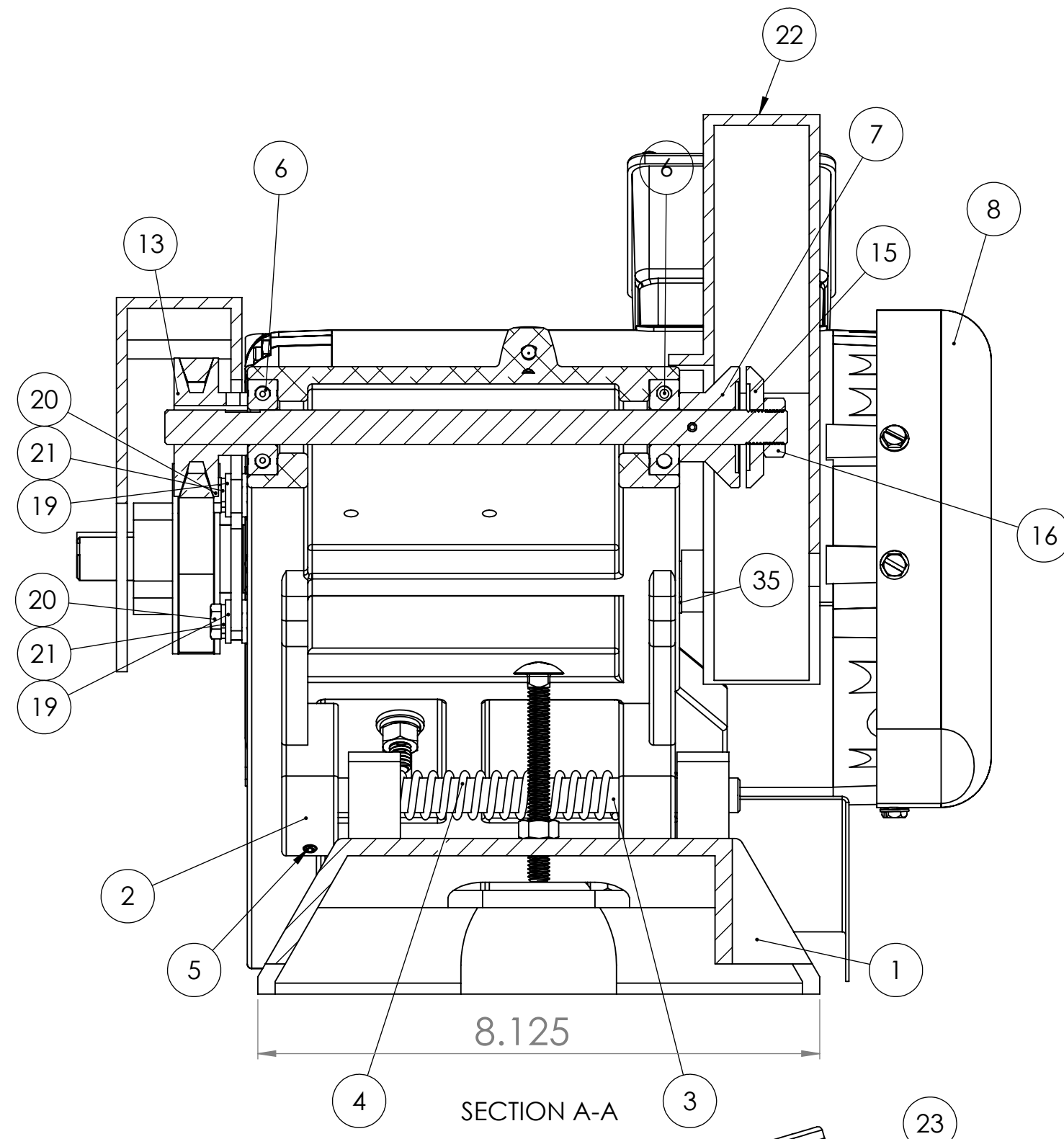

SECTION A-A

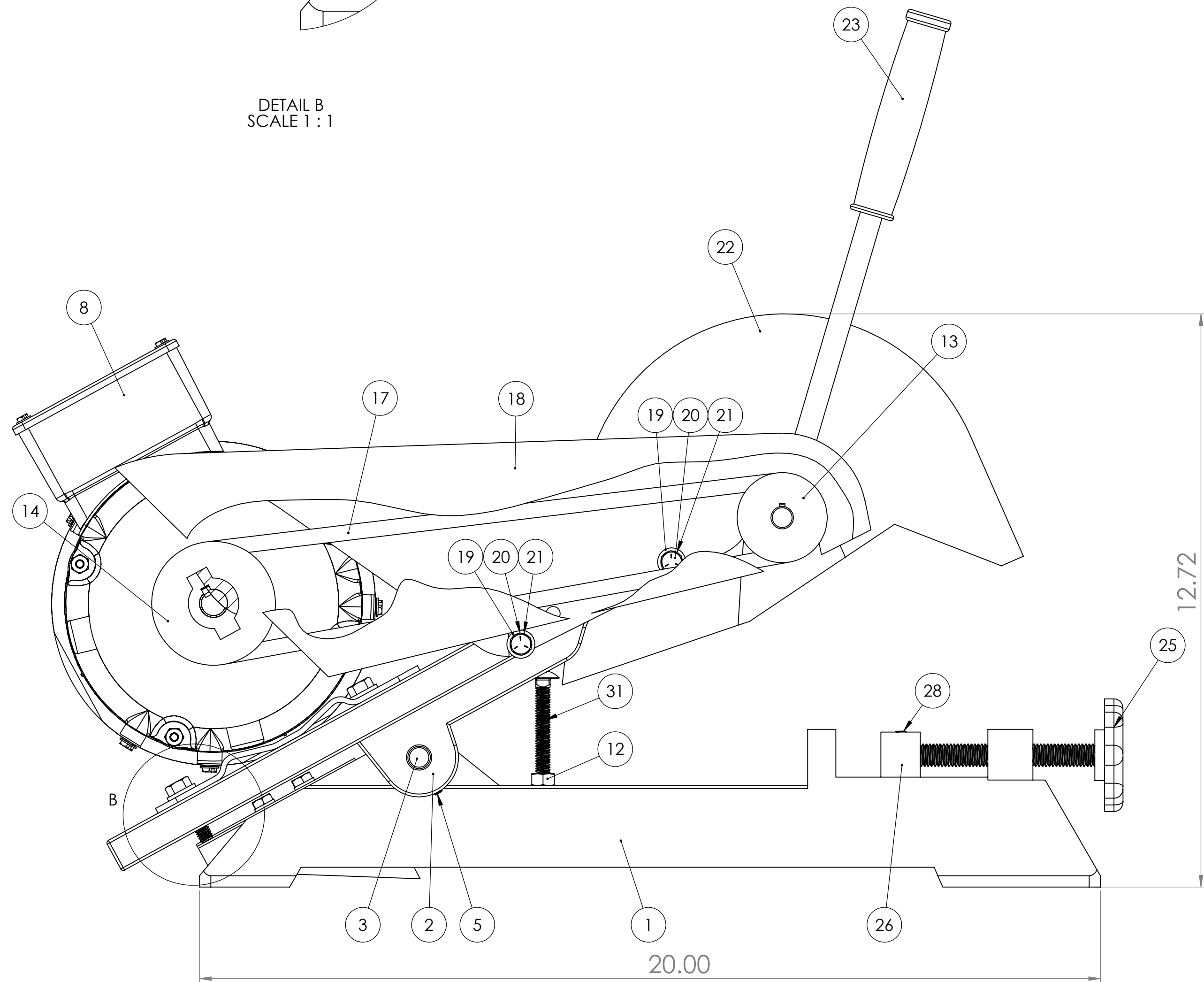
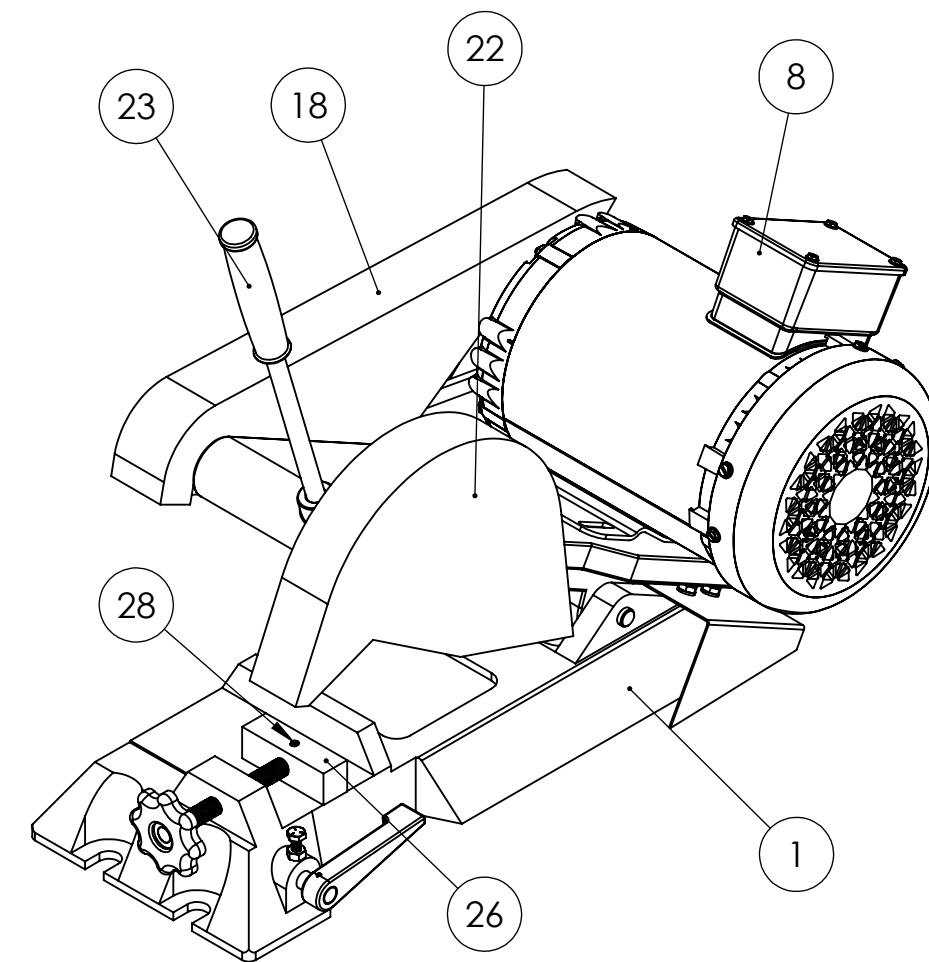

ROLA012016 LOCATION

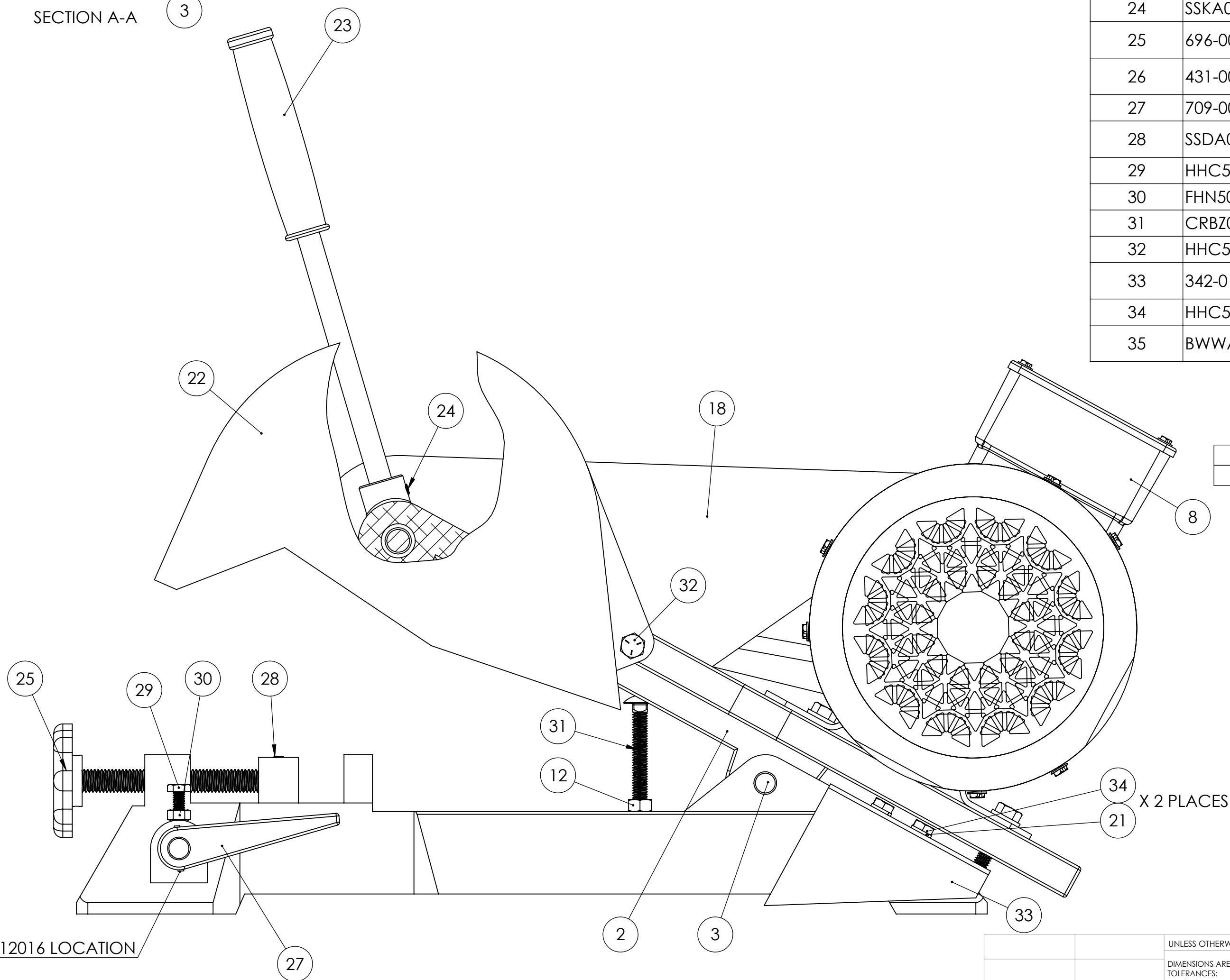

ITEM NO.	PART NUMBER	DESCRIPTION	QTY.
1	050-001	K7B- K8B SAW BASE	1
2	002-001	ALUMINUM SAW ARM FOR K7B, K8B, K10B (TAKES NEW 6202-2RS-1/2 BEARINGS)	1
3	562-004	TRUNNION PIN FOR K7B, K8B, K10B	1
4	697-013	TENSION SPRING FOR 2FS, 2FS72, 2FSM, BG142, 2FS72M, K12-14B	1
5	SHCA010006	10-24 X 3/8 SHCS CUP POINT	1
6	044-012	BEARING FOR K7B, K8B, 6202-2RS-1/2	2
7	701-012	SPINDLE WITH TIGHT FLANGE FOR K7B-K8B	1
8	486-007	3HP FOR K8B, K10B, KM10, BG260H, S460W, S6M AND S612	1
9	HHC5031020	5/16-18 X 1-1/4 HHCS GR 5 Z	3
10	UFWZ031	5/16 USS F/W Z	6
11	SLWZ031	5/16 SPLIT L/W Z	3
12	FHN5031	5/16-18 FHN GR5 ZINC	4
13	560-003	SPINDLE PULLEY FOR K7B-K8B	1
14	560-004	MOTOR PULLEY FOR K7B, K8B, 2FS, 2FS72M	1
15	292-002	LOOSE FLANGE FOR K7B, K8B	1
16	FJNZ051	1/2-20 F H JAM NUT Z	1
17	051-001	V-BELT FOR K7B, K8B, 2FS AND 2FS72M (OLD STYLE)	1
18	342-002	BELT GUARD FOR K7B AND K8B	1
19	UFWZ025	1/4 USS F/W Z	4
20	HHC5025012	1/4-20 X 3/4 HHCS GR5 Z	2
21	SLWZ025	1/4 SPLIT L/W Z	4
22	342-001	WHEEL GUARD FOR K7B AND K8B	1
23	381-003	HANDLE W GRIP FOR K7B, K8B, K10B SAWS	1
24	SSKA025004	1/4-20 X 1/4 SOC SET KNURL PT.	1
25	696-002	WISE SCREW ASSEMBLY FOR K7B, K8B	1
26	431-003	JAW, VISE BLOCK FOR K7B AND K8B SAWS	1
27	709-001	WORK STOP FOR K7B, K8B SAWS	1
28	SSDA025006	1/4-20 X 3/8 SOC SET FULL DOG PT	1
29	HHC5025016	1/4-20 X 1 HHCS GR5 Z	1
30	FHN5025	1/4-20 FHN GR5 Z	1
31	CRBZ031048	5/16-18 X 3 CARRIAGE BOLT Z	1
32	HHC5031024	5/16-18 X 1-1/2 HHCS GR5 Z	1
33	342-011	GUARD, SPARK DEFLECTOR FOR K8 3HP SAWS ONLY	1
34	HHC5025008	1/4-20 X 1/2 HHCS GR5 Z	2
35	BWWA031	5/16 BOWED SPRING WASHER 21/64	1

3PH 1PH MOTOR

ITEM NO.	PART NUMBER	DESCRIPTION	QTY.
8	486-006	3HP 1PH	1

PROPRIETARY AND CONFIDENTIAL
THE INFORMATION CONTAINED IN THIS DRAWING IS THE SOLE PROPERTY OF KALAMAZOO INDUSTRIES, INC. ANY REPRODUCTION IN PART OR AS A WHOLE WITHOUT THE WRITTEN PERMISSION OF KALAMAZOO INDUSTRIES, INC. IS PROHIBITED.

UNLESS OTHERWISE SPECIFIED: DIMENSIONS ARE IN INCHES TOLERANCES: FRACTIONAL: ± ANGULAR: MACH ± TWO PLACE DECIMAL: ± THREE PLACE DECIMAL: ± INTERPRET GEOMETRIC TOLERANCING PER: MATERIAL: FINISH: NEXT ASSY USED ON APPLICATION	DRAWN CHECKED ENG APPR. MEG APPR. Q.A. COMMENTS:	NAME DATE	KALAMAZOO INDUSTRIES, INC. TITLE: 8" SAW ASSEMBLY W 3HP MOTOR SIZE DWG. NO. D K8B-3HP SCALE: 1:2 WEIGHT: SHEET 1 OF 1
--	---	--------------	---