

INSTRUCTION MANUAL

HSM14



**KALAMAZOO
INDUSTRIES, INC.**

6856 East K Avenue
Kalamazoo, MI 49048

269-382-2050 PH

269-382-0790 FAX

www.kalamazooindustries.com

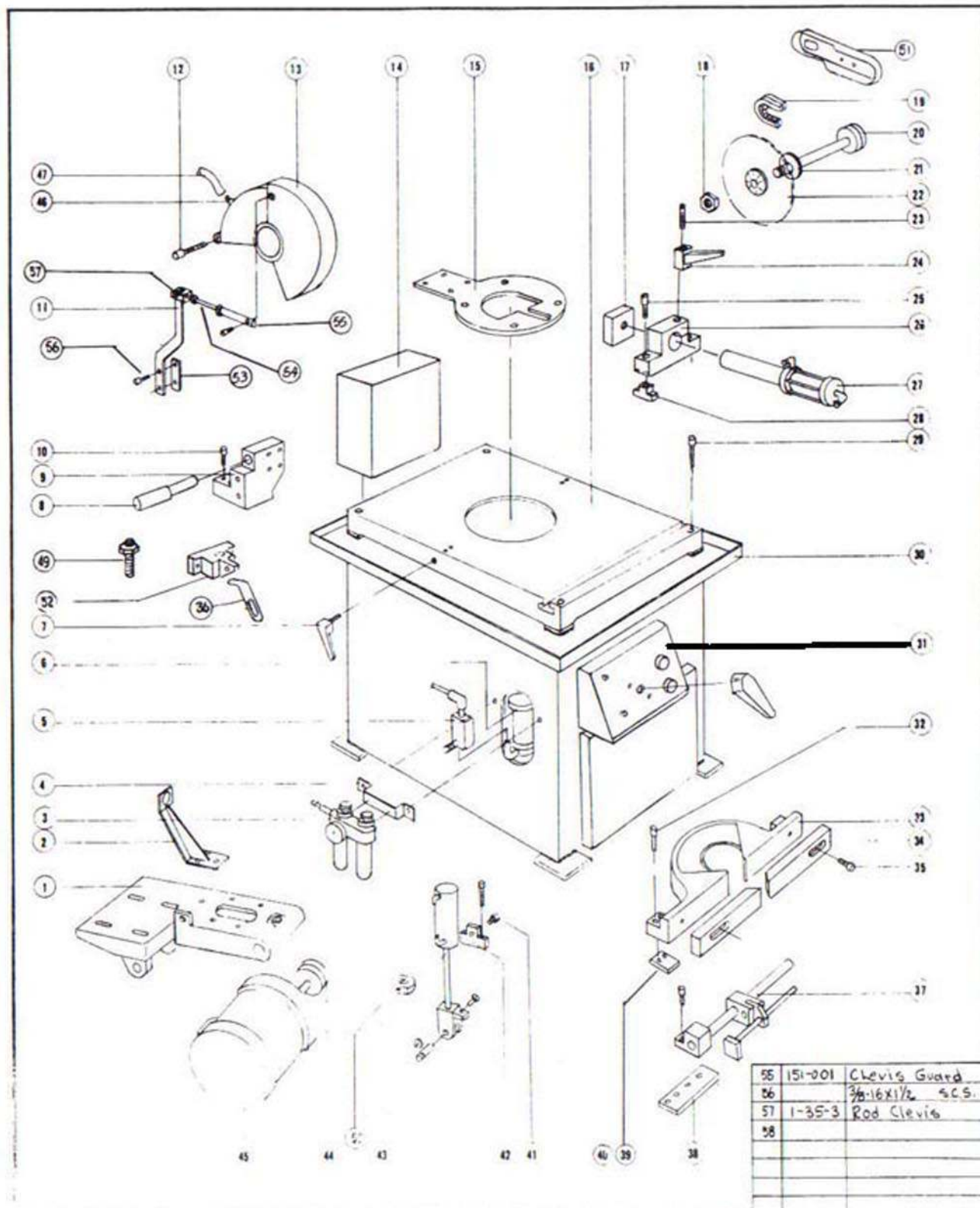

ITEM	PART No.	DESCRIPTION	QTY
1	002-024	SAW ARM	1
2	041-039	Hose BRACKET	1
3	641-011	Adjuster Nut	1
4		Regulator Brkt	1
5		Flow Control	1
6	641-010	RESERVOIR	1
7	454-008	TABLE Lock	1
8	562-019	TRUNNION PIN	1
9	833-022	TRUNNION	1
10		5/8-16X1 1/2 SCS	4
11	455-007	Lever	1
12		5/8X2 1/2 spacer	1
13	342-072	Wheel Guard	1
14	A1212CH	Elect Box	1
15	556-045	Miter Plate	1
16	050-043	Base	1
17	431-013	Jaw Vise	2
18		1-14 Nut(LH)	1
19	051-006	V-Belt 3V375	2
20	560-001	SPINDLE PULLEY	1
21	701-002	SPINDLE FLANGE	1
22	292-020	Flange Loose	1
23		1/2-13X3 SS	2
24	454-005	VISE LOCK	2
25		1/2-13X2 1/2	4
26	041-038	BRKT. Mfg.	2
27		AIR VISE CYL.	2
28		1/2-13 T-NUT	4
29		1/2-13X3 3/4 SCS	4
30	716-021	Base Assr.	1
31	540-003	Panel Control	1
32		1/2-13X2 1/2 SCS	4
33	264-017	Fence	1
34	556-046	Plate Fence	2
35		1/4-20X1 1/4 SCS	4
36		CAM STOP	1
37		Work Stop Assr.	1
38	699-031	Spacer Fence	1
39	699-030	Spacer Fence	1
40			
41		1/4-20X1/2 Spacer	2
42	041-037	BRKT. CYL.	2
43	130-014	CYLINDER	1
44	560-002	Motor Pulley	1
45		S.H.P.-3PH Motor	1
46		Coolant Valve	1
47		Coolant Hose	1
48	912-013	Valve (3P)	2
49	696-024	Scrub Stop	1
50	053-027	Block Cyl. Mfg.	1
51	342-004	Belt Guard	1
52	041-040	BRKT Trunnion	1
53	699-032	Spacer Lever	1
54		1/2-13X3	1

55	151-001	Clevis Guard	1	HSM14 14" blade, 1" arbor SCALE: N/A APPROVED BY: _____ DATE: _____ DRAWING NUMBER: _____
56		3/8-16X1 1/2 SCS	2	
57	1-35-3	Rod Clevis	1	
58				

Kalamazoo Industries, Inc.

WARNING!

TO REDUCE THE RISK OF FIRE OR SHOCK HAZARD,
DO NOT EXPOSE THIS EQUIPMENT TO RAIN, ANY LIQUID OR MOISTURE.

READ AND UNDERSTAND ALL SAFETY PRECAUTIONS AND OPERATING INSTRUCTIONS BEFORE OPERATING UNIT

OPERATING INSTRUCTIONS

INSPECT YOUR NEW UNIT CAREFULLY FOR SIGNS OF SHIPPING DAMAGE. IF DAMAGED, PLEASE CONTACT CARRIER AND SUBMIT A CONCEALED DAMAGED REPORT. DO NOT RETURN GOODS TO US WITHOUT OUR RGA NUMBER AND SHIPPING INSTRUCTIONS. SEE BACK PAGE FOR RETURN POLICY AND WARRANTY.

BEFORE STARTING OR CONNECTING ELECTRICALS VERIFY THE PHASE AND VOLTAGE OF THE UNIT.

BE SURE MACHINE IS BALANCED CORRECTLY SO IT WILL NOT TIP OVER.

TO GUARD AGAINST CONCEALED DAMAGE, STAND CLEAR AND OBSERVE UNIT FOR THE FIRST FEW MINUTES OF OPERATION. GUARDS MUST NEVER BE REMOVED.

ABRASIVE SAW SAFETY

NEVER REMOVE SAFETY GUARDS FROM MACHINE. DISCONNECT POWER SOURCE BEFORE MAKING ANY MACHINE ADJUSTMENTS

ELECTRIC MACHINES ARE NOT INTENDED FOR USE IN OR NEAR WATER. THIS INCLUDES AN OPERATOR STANDING ON A WET FLOOR.

DO NOT USE AROUND FLAMMABLE MATERIALS OR LIQUIDS.

MACHINES SHOULD BE OPERATED IN VENTILATED AREAS.

ALWAYS WEAR SAFETY GLASSES OR A FULL FACE SHIELD FOR PROTECTION.

KEEP HANDS CLEAR OF THE CUTTING AREA.

DO NOT WEAR GLOVES OR LOOSE FITTING CLOTHES WHEN OPERATING THIS MACHINE.

ALWAYS KEEP HAIR TIED BACK OR COVERED.

ALWAYS KEEP FLANGES CLEAN AND TIGHT AGAINST CUTTING WHEEL.

ABRASIVE MACHINES ARE FOR ABRASIVE WHEELS NOT STEEL TOOTHED BLADES. DO NOT ATTEMPT TO USE STEEL BLADES UNLESS CORRECTLY GUARDED WITH AN ENCLOSED WHEEL GUARD. KEEP STEEL BLADES FULLY RETRACTED INTO WHEEL GUARD WHEN DONE CUTTING.

ALWAYS KEEP WHEEL GUARD IN DOWN POSITION.

BE SURE WORK PIECE IS CLAMPED SECURELY IN VISE BEFORE CUTTING.

WARNING!!!

IMPROPER USE MAY CAUSE BREAKAGE AND SERIOUS INJURY.

DO

1. DO always handle and store wheels in a careful manner.
2. DO visually inspect all wheels before mounting for possible damage.
3. DO check machine speed against the established maximum safe operating speed marked on the wheel.
4. DO check mounting flanges for equal and correct diameter.
5. DO use mounting blotters when supplied with wheels.
6. DO always use a safety guard covering at least one-half of the abrasive wheel.
7. DO allow newly mounted wheels to run at operating speed, with guard in place, for at least one minute before cutting.
8. DO always wear safety glasses or some type of eye protection when cutting.

DON'T

1. DON'T use a cracked wheel or one that has been dropped or has become damaged.
2. DON'T force a wheel onto the machine or alter the size of the mounting hole-if wheel won't fit the machine, get one that will.
3. DON'T ever exceed maximum operating speed established for the wheel.
4. DON'T use mounting flanges on which the bearing surfaces are not clean, flat and free of burrs.
5. DON'T tighten the mounting nut excessively.
6. DON'T start the machine until the wheel guard is in place.
7. DON'T jam work into wheel.
8. DON'T force cutting so that motor slows noticeably or work gets hot.
9. DON'T wear gloves when operating machine.

Kalamazoo Industries, Inc.
Kalamazoo, Mi.
PH: 269-382-2050

HSM-14
5 hp. Non-ferrous saw, Semi -automatic
14" blade, 1" arbor
Mitre 45 deg. Left/Right

Basic Controls

Sawhead feedrate Control- Controls sawhead downfeed speed.

Downstop Adjustment- Adjust for sawblade depth control.

Stop- Stops sawhead motor.

Start- Starts sawhead motor

Vise Open/Close- Rotate to open/close vises.

Sawhead UP- Push to bring sawhead feed DOWN.

Sawhead Down- Push to bring sawhead UP. Button may be actuated anytime during cycle to bring sawhead UP.

Air In- 0-65 PSI. Use dry shop air. Wet air corrodes valves.

Hydraulic reservoirs- Use DTE 24 hydraulic oil. Oil reservoirs alternate levels. $\frac{3}{4}$ full, $\frac{1}{4}$ full.

Mitre Table Lock- Locks sawhead . Release and rotate to desired angle, re-lock.

Kalamazoo Industries, Inc.
6856 East K Ave.
Kalamazoo, Mi. 49048
269-382-2050
Model HSM-14
5 hp.
14" blade
Non-ferrous

Sawhead feedrate control

Downstop Adjustment

Vise ON/OFF

Mitre Table LOCK

Stop

Start

Vise Open/Close

Sawhead UP

Sawhead Down

DTE 24
Hyd. Oil

Shop Air IN
0-65 PSI

