

ITEM NO.	PART NUMBER	DESCRIPTION	QTY.
1	050-002	K12-14 SAW BASE	1
2	831-022	TRUNNION ASSEMBLY FOR HSM14, HS14, K12-14MS	1
3	ZERKO12000	1/8-27 X 1 1/16 STRT LUBE FITTING	1
4	HHC5031024	5/16-18 X 1-1/2 HHCS GR5 Z	4
5	SLWZ031	5/16 SPLIT L/W Z	10
6	562-034	PIN, TRUNNION FOR HS14 AND K12MS W/PH (SHORT)	1
7	002-002	K12- 14 SAW ARM	1
8	SSKA031006	5/16-18 X 3/8 SOC SET KNURL PT.	1
9	044-001	K12 BEARING	2
10	701-002H5	SPINDLE W TIGHT FLANGE (STEEL) FOR KM14HS, KM14SC, HSM14, HS14	1
11	292-020	LOOSE FLANGE (STEEL) FOR HSM14	1
12	537-026	L.H. SPINDLE NUT 1"-14 FOR K14, KM14	1
13	486-001	5 HP MOTOR FOR K12B, K14B, KM14, KM14HS & 56MS-SHP	1
14	HHC5037020	3/8-16 X 1-1/4 HHCS GR5 Z	4
15	UFWZ037	3/8 USS F/W Z	4
16	SLWZ037	3/8 SPLIT L/W Z	4
17	FHN5037	3/8-16 FHN GR5 Z	4
18	560-001	K12- 14 SPINDLE PULLEY	1
19	SSKA025004	1/4-20 X 1/4 SOC SET KNURL PT.	3
20	049-022	MOTOR PULLEY SHEAVE FOR K12B, K14B AND KM14	1
21	560-002	MOTOR PULLEY SHEAVE FOR K12-14B, K12-14W, K12-14MS AND KM14	1
22	051-006	3V375 V-BELT (2 REQUIRED) FOR K12, K14, KM14 SAWS	2
23	342-086	K12-14 INNER BELT GUARD ASSEMBLY FOR PLASTIC GUARD	1
24	RND-0-31-18THRD X3.75	3-3/4 INCHES OF 5/16-18 THREADED ROD	1
25	UFWZ031	5/16 USS F/W Z	6
26	FHN5031	5/16-18 FHN GR5 ZINC	6
27	CPNZ031	5/16-18 CAP NUT NICKEL	1
28	342-004	K12-14 OUTER BELT GUARD/PLASTIC	1
29	HHC5031020	5/16-18 X 1-1/4 HHCS GR 5 Z	1
30	HHC5031012	5/16-18 X 3/4 HHCS GR5 Z	1
31	431-002	K10- 14 REAR VISE JAW	2
32	SHCA031048	5/16-18 X 3 SHCS	4
33	537-014	K10-14 FENCE NUT	1
34	053-032	BLOCK, SCREW VISE FOR HS14	2
35	SHCA031032	5/16-18 X 2 SHCS	20
36	832-020	TUBE, SCREW VISE FOR HS14	2
37	537-020	NUT, SCREW VISE COLLAR FOR HS14	2
38	696-026	HS14 VISE SCREW	2
39	431-020	SCREW VISE JAW FOR HS14	2
40	SSDA031016	5/16-18 X 1 SOC SET FULL DOG	2
41	342-072	WHEEL GUARD ASSEMBLY FOR HSM14 AND HS 14	1
42	HHC5025008	1/4-20 X 1/2 HHCS GR5 Z	3
43	SSBA062044	5/8 X 2-3/4 SOC SHOULDER BOLT	1
44	699-032	SPACER, LEVER FOR HSM14	2
45	455-007	LEVER ASSEMBLY, WHEEL GUARD FOR HSM14	1
46	HHC5031032	5/16-18 X 2 HHCS GR5 Z	2
47	455-007BRACKET	TENSION BRACKET FOR HSM14 WHEEL GUARD LEVER ASSEMBLY	1
48	BSCA025012	1/4-20 X 3/4 BSCHCS	1
49	SLWZ025	1/4 SPLIT L/W Z	5
50	FHN5025	1/4-20 FHN GR5 Z	3
51	455-007ROD	GUIDE ROD FOR K10 AND K14 SERIES CLAMSHELL WHEEL GUARD LEVER ASSEMBLY	1
52	ROLA012008	1/8 X 1/2 ROLL PIN	1
53	053-047	BLOCK, WHEEL GUARD FOR K10 AND K14 SERIES CLAMSHHELL GUARD	1
54	SHCA025016	1/4-20 X 1 SHCS	1
55	441-015	907B-2500-1.005 1/4 THUMBSCREW 1-1/2 DIA	1
56	RND-0.625-11THRD X3.562	3-9/16 INCHES OF 5/8-11 THREADED ROD	1
57	FHN5062	5/8-11 FHN GR5 Z	1
58	041-118	DOWN STOP BRACKET ASSEMBLY, FOR HS14	1
59	HHC5025012	1/4-20 X 3/4 HHCS GR5 Z	2
60	FJNZ062	5/8-11 F H JAM NUT Z	1
61	RND-0.625-11THRD X4.5	4-1/2 INCHES OF 5/8-11 THREADED ROD	1
62	381-002	HANDLE W GRIP FOR K12-14 SAWS	1
63	381-020	HS14 VISE HANDLE	2
64	041-057	SWITCH BRACKET FOR K12-K14	1

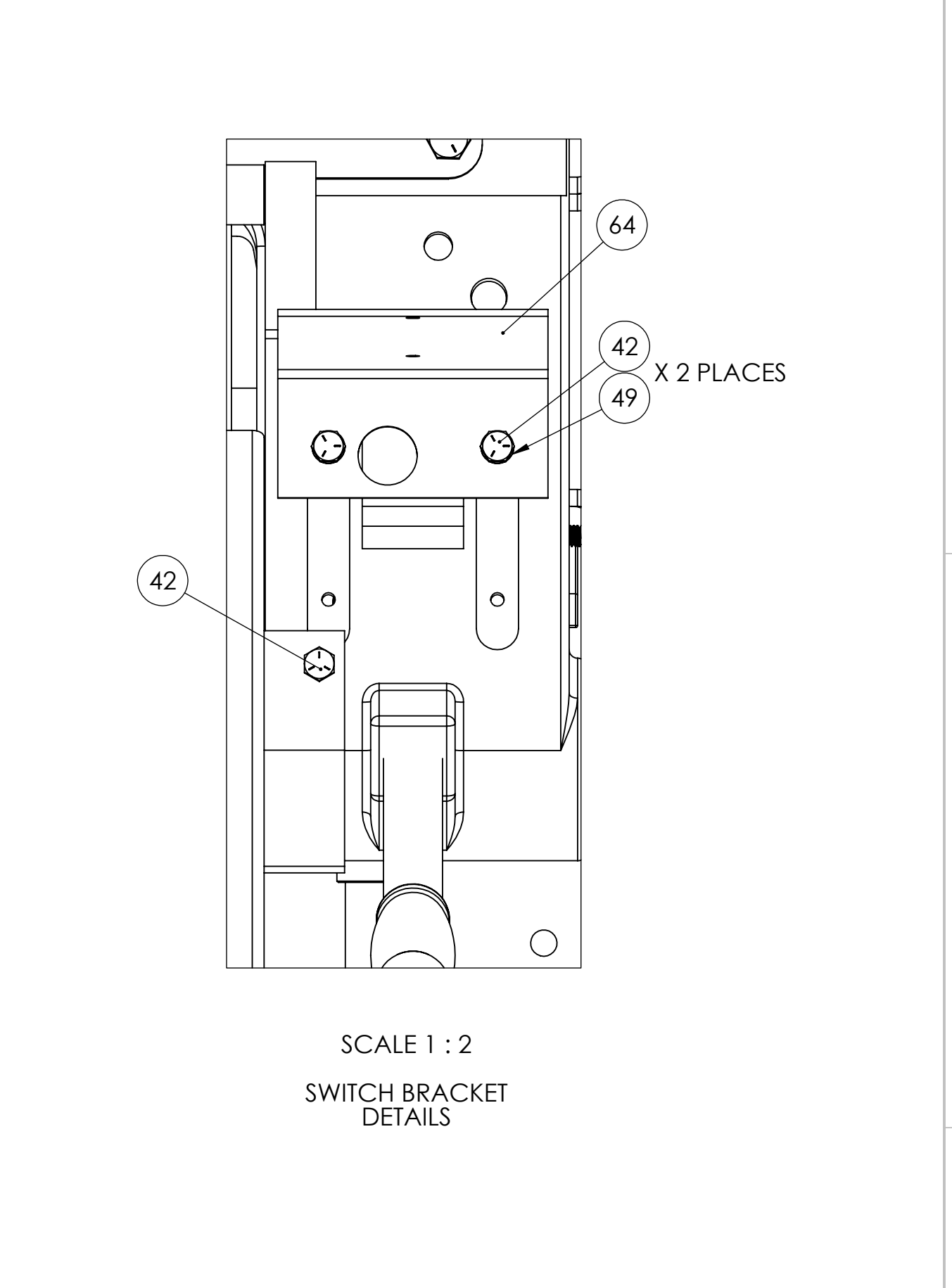

UNLESS OTHERWISE SPECIFIED:	DRAWN	NAME	DATE
DIMENSIONS ARE IN INCHES	CHECKED		
TOLERANCES:	ENG APPR		
FRACTIONS 1/16	ENG APPR		
ANGULAR 30/30	ENG APPR		
PROFILES DECIMAL 1	ENG APPR		
THREE PLACE DECIMAL 2	ENG APPR		
INTERFERENCE GEOMETRIC TOLERANCES PER	COMMENTS:		
ASSEMBLY			
NEED ASSIST	USED ON	FINISH	
APPLICATION	DO NOT SCALE DRAWING		

**KALAMAZOR**  
**HIGH SPEED NON FERROUS SAW**  
 TITLE  
 SIZE DWG. NO. REV  
**E HS14**  
 SCALE: 1:5 WEIGHT: SHEET 1 OF 1