

DETAIL B
SCALE 1 : 1
IDLER PULLEY DETAIL

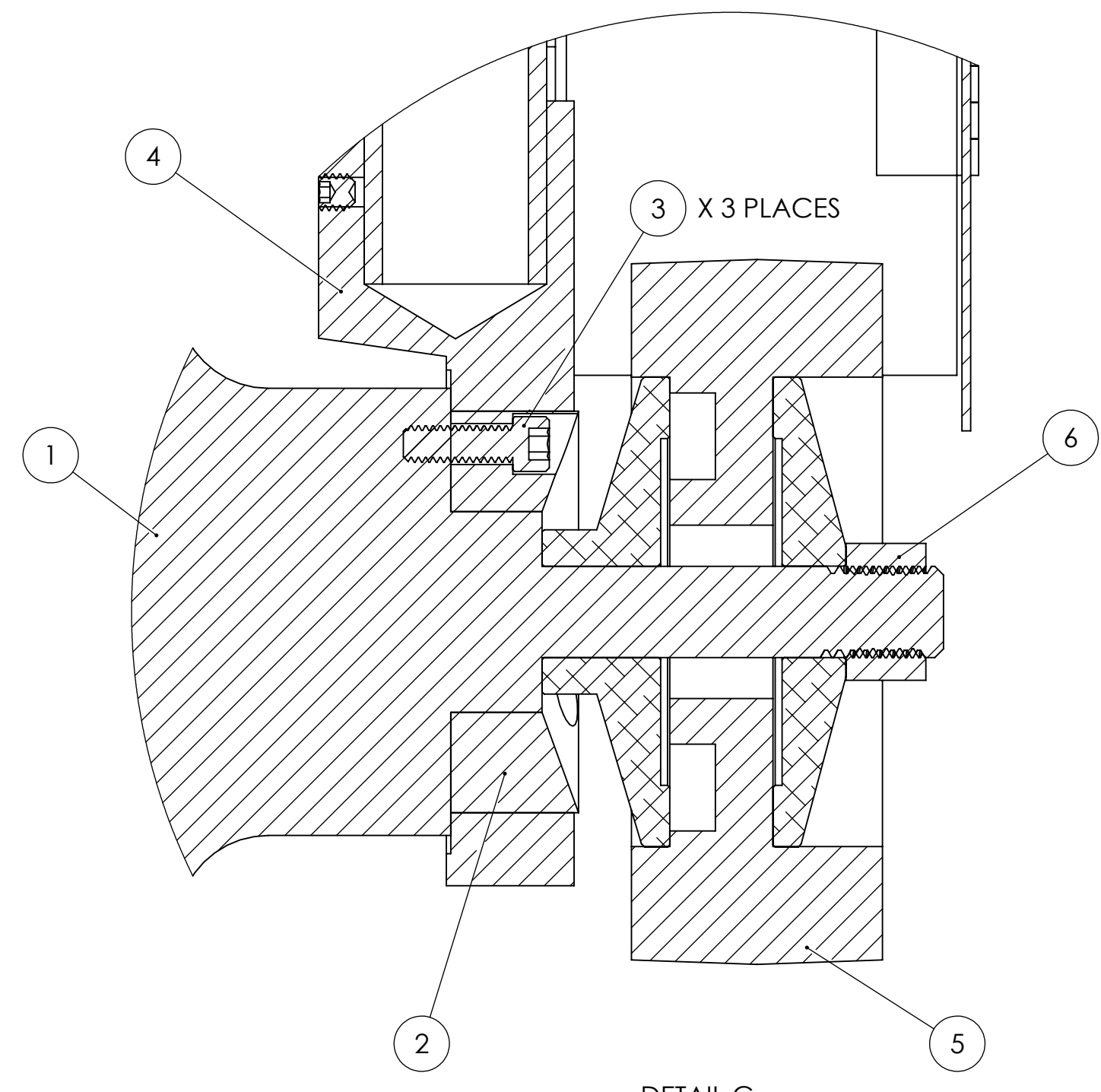

DETAIL C
SCALE 1 : 1
DRIVE PULLEY DETAIL

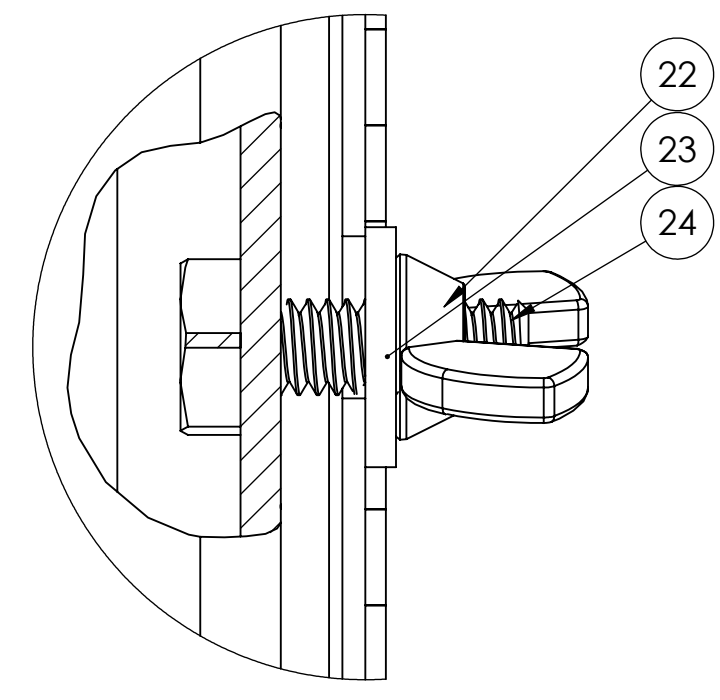

DETAIL D
SCALE 2 : 1
BELT GUARD LATCH
DETAILS

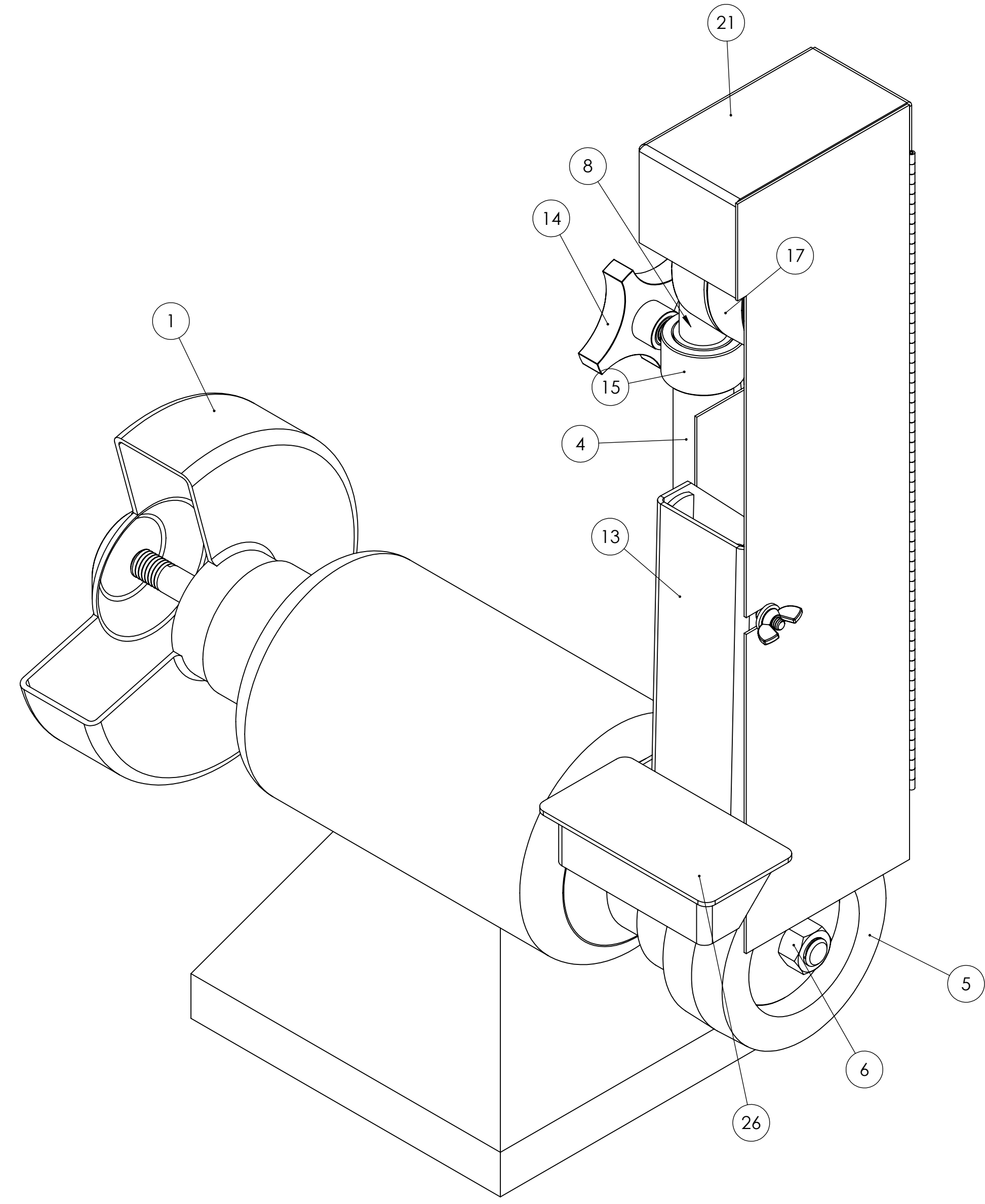

ITEM NO.	PART NUMBER	DESCRIPTION	QTY.
1	486-026	1/2HP MOTOR BENCH TOP GRINDER UNIT FOR 2SK7	1
2	123-005	ADAPTOR RING-2SK7 FOR BALDOR MOTOR	1
3	SHCA025012	1/4-20 X 3/4 SHCS	3
4	291-009	2FS, 2SK7 FRAME ASSEMBLY, BRACKET AND TUBE (FOR OLD STYLE DS10-2M)	1
5	936-008	WHEEL, DRIVE FOR 2SK7 SANDER	1
6	FHN5062	5/8-11 FHN GR5 Z	1
7	697-013	TENSION SPRING FOR 2FS, 2FS72, 2FSM, BG142, 2FS72M, K12-148	1
8	645-008	TENSION ROD FOR 2FS, 2FSM, 2FS72, 2SK7 SANDERS	1
9	HHC5031032	5/16-18 X 2 HHC5 GR5 Z	2
10	FHN5031	5/16-18 FHN GR5 ZINC	2
11	SLWZ031	5/16 SPLIT L/W Z	3
12	UFWZ031	5/16 USS F/W Z	3
13	550-007	STANDARD PLATEN FOR 2 X 48 SANDERS	1
14	441-011	TRACKING KNOB FOR 2FS, 2FS72, 2FSM, 2SK7 SANDERS	1
15	123-004	TRACKING COLLAR FOR 2FS, 2FS72, 2FSM, 2SK7, BG142	1
16	SSKA031006	5/16-18 X 3/8 SOC SET KNURL PT.	1
17	936-030	STEEL IDLER PULLEY, NEW STYLE FOR 2FS, 2FSM, 2SK7	1
18	004-006	ADAPTOR FOR 936-003 IDLER PULLEY	1
19	HHC5037040	3/8-16 X 2-1/2 HHC5 GR5 Z	1
20	SLWZ037	3/8 SPLIT L/W Z	1
21	342-018	GUARD, HINGED OSHA FOR 2FS, 2FSM, 2SK7 SANDERS	1
22	WGNZ025	1/4-20 FORGED WING NUT Z	1
23	UFWZ025	1/4 USS F/W Z	3
24	HHC5025012	1/4-20 X 3/4 HHC5 GR5 Z	1
25	HHC5031012	5/16-18 X 3/4 HHC5 GR5 Z	1
26	829-004	WORK TABLE FOR 2', 4\", DS10-4 SANDERS	1
27	455-012	LEVER FOR 2FSM	1
28	PR-AD66ABSLF	3/16 X 1/4-3/8 POP RIVET LARGE FLANGE ALUM/ALUM FOP	1
29	MSWZ010	#10 M.S. F/W Z	1

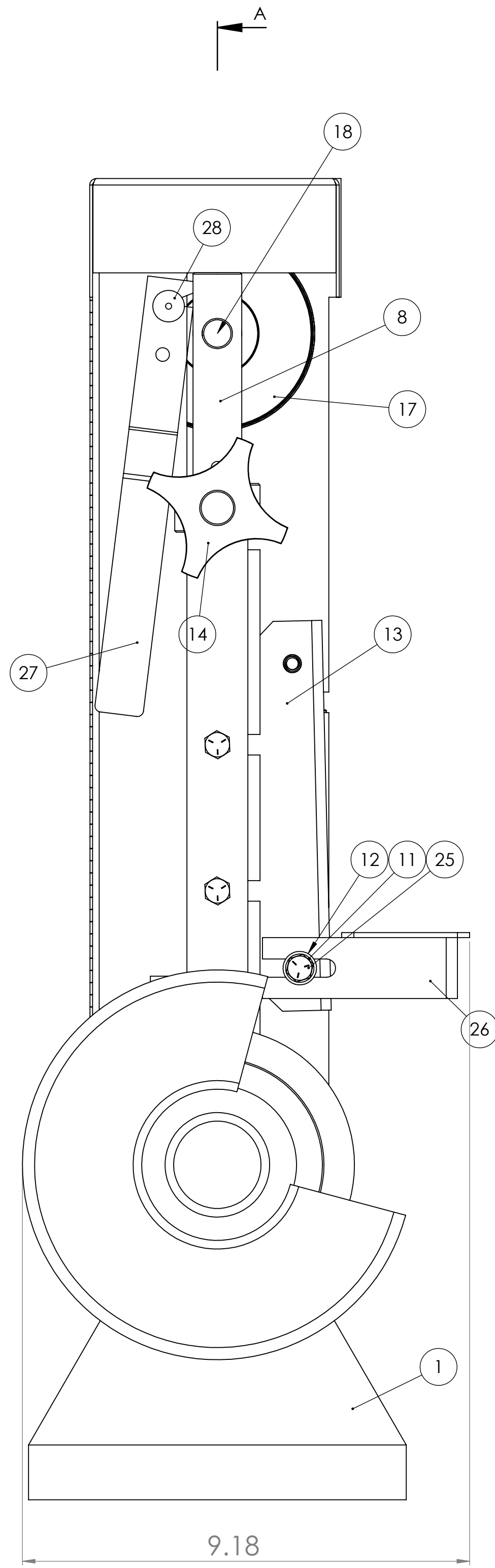

9.18

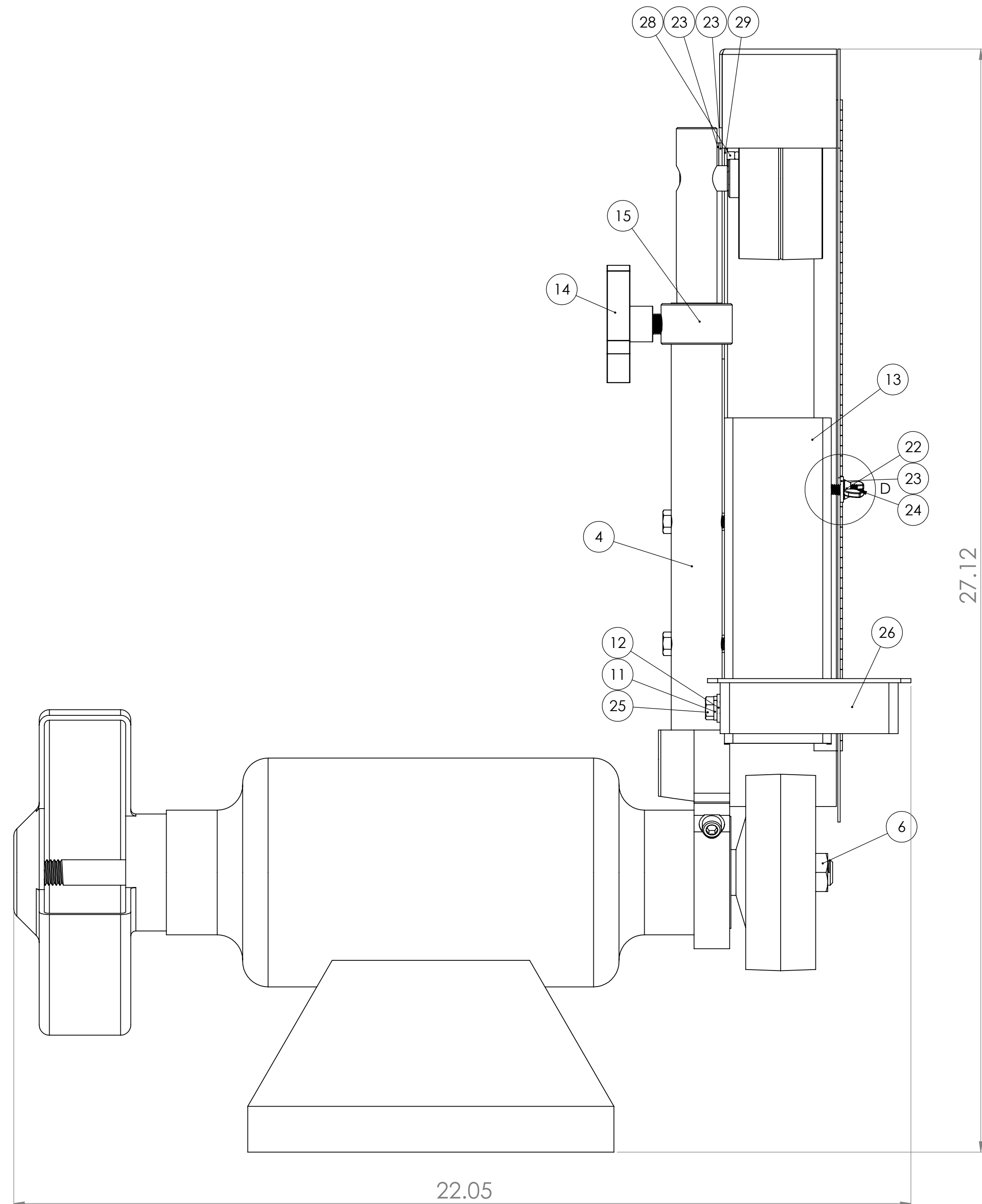

22.05

27.12

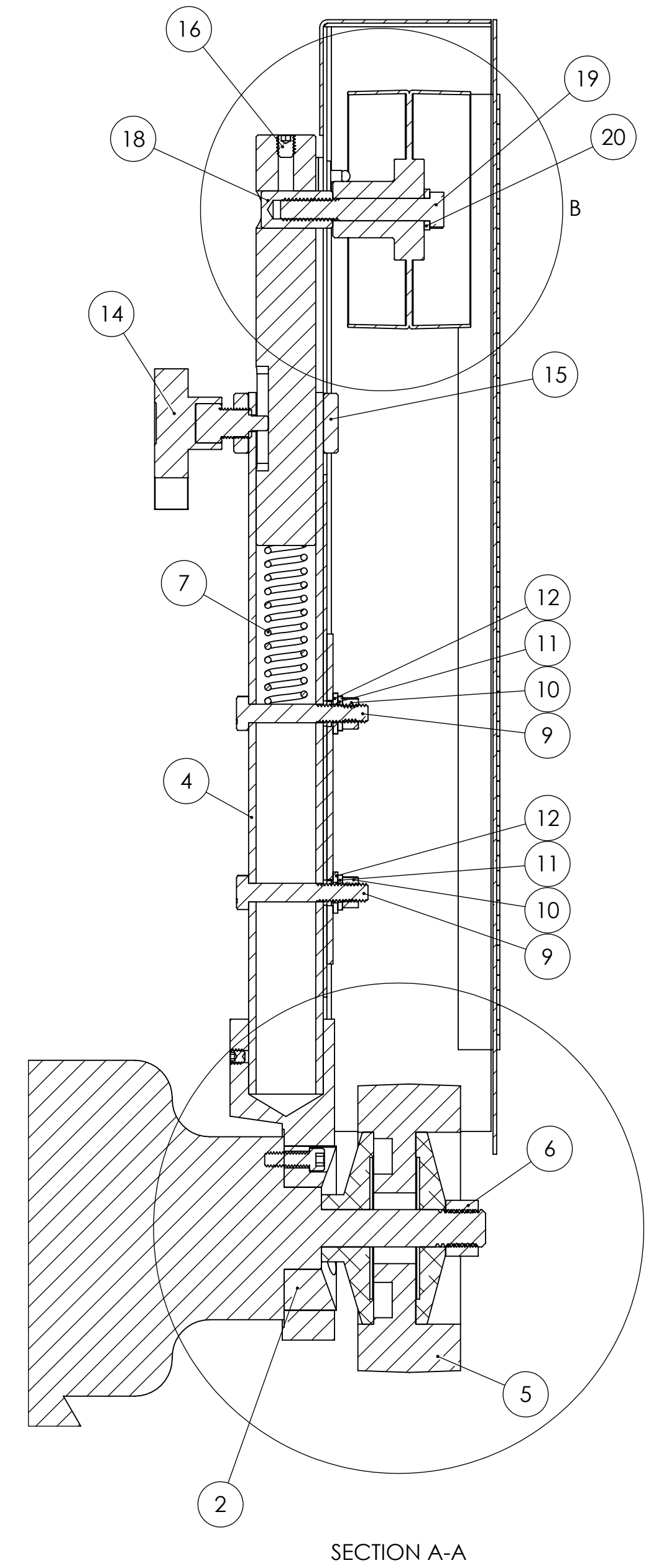

SECTION A-A

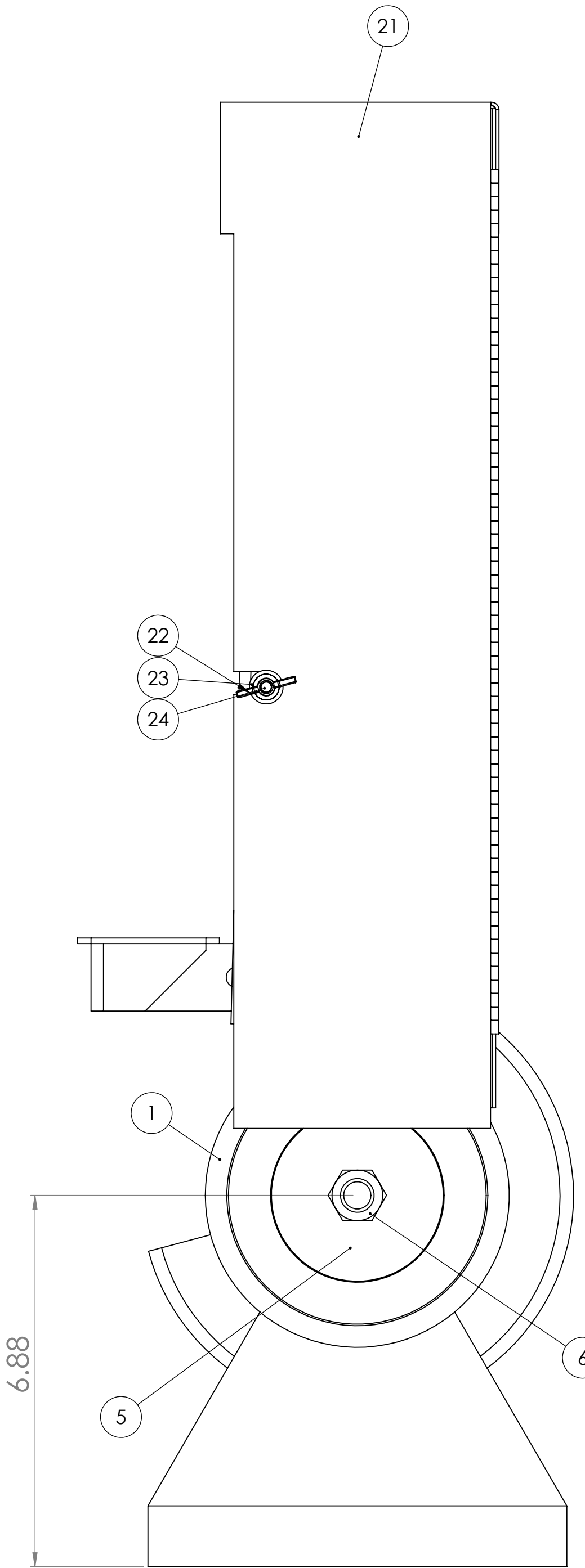

6.88

UNLESS OTHERWISE SPECIFIED:
DIMENSIONS ARE IN INCHES
TOLERANCES:
FRACTIONS ± .005
DECIMALS ± .001
THREE PLACE DECIMAL ± .0005
INTERFERENCE GEOMETRIC TOLERANCES PER ASME Y14.5-2009

PROPRIETARY AND CONFIDENTIAL
THIS DRAWING IS THE PROPERTY OF KALAMAZOO TOOL COMPANY
REPRODUCTION IN PART OR AS A WHOLE WITHOUT THE WRITTEN PERMISSION OF KALAMAZOO TOOL COMPANY IS PROHIBITED.

APP. NO.	DATE	NAME	DATE	NAME

TITLE: **2 X 48 BELT SANDER/7\"/>**

SCALE: 1:2 WEIGHT: SHEET 1 OF 1